

# New Application Awards 2019





## Contents

Message of the Secretary-General

### Best New Technology Case Studies

Stainless Steel Bicycle

C 2 Fresh Water

Stainless Steel Sheet as used in Turbine Housing  
[CK-SMiTH]

KAGRA, Large-scale Cryogenic Gravitational-  
wave Telescope of Japan

Fukuoka Bar Association Hall

Folded stainless steels create a new concept  
in bend-formed body structures for small  
electrified urban vehicles

Ferritic stainless steel with enhanced formability  
for exhaust systems of hybrid and plug-in  
hybrid vehicles

### Best New Development Case Studies

Extension of Monaco to the Sea

Stainless steel in rehabilitation of historical  
heritage

Urban waste sorting/recovery container

Martensitic Stainless Steel for Knife Blades and  
Cutting Tools

Stainless Steel Floor for Garbage Truck Hoppers  
Concrete Mixer Truck

Stainless steel electrical enclosures

Stainless Steel for Hard Disk Drive (HDD) Cover

Stainless steel floors for bumper cars

Stainless Steel Power Pack

Brescia metro stations

Exhaust Gas Recirculation (EGR) Pre-Cooler

Leisure and Commercial Hardtop Storage  
Solutions

NDF 250-man Mobile Kitchen

FRACTAL Stainless Steel Tiles

Façade of interior pedestrian hall at Mexico City  
International Airport

Façade of Liverpool Plaza Tereo Department  
Store

Stainless Steel leading the way to a Safe and  
Sustainable future

A box for home delivery

Lining for flue duct

RFID applied stainless steel food waste  
measuring & paying equipment

Seismic brace for STS pipe

The sediment discharging facility at the Biratori  
Dam

The Lock Gates of Miyako City Ferry Terminal  
Conveyor Belt Self Unloading Stainless Steel

Trailers

Stainless Steel Highway Sound Barriers

Stainless Steel Yacht

Innovative modular concept for wastewater  
treatment tanks

Therma grade for a baking furnace used to  
produce catalysts for oil refining

First use of duplex stainless steel Forta LDX  
2404, UNS82441 in a major bridge building  
project

Lightweight stainless steel fuel filler neck for  
automobiles

Stainless Steel New Applications in Nigeria  
High Nitrogen (above 2000ppm) and Low Nickel  
(~3.0%) alloyed High Strength Austenite  
Stainless Steel (QN1803/304D) with no less  
Pitting Corrosion Resistance than standard  
304



## Foreword by the Secretary-General



There is only one way in which the overhang of global production capacity can be countered in the long run and that is by applying more intellectual resources towards the development of new ideas towards the creation of new consumption for stainless steel. To that end, we have been encouraging members to share their work on market development, thus providing inspiration to others in the industry. This type of pooled effort eventually begins to spread outwards, like the ripples of a pond. Then the process must begin again – relentlessly driving new market potential. One of our key projects this year has been an investigation of markets where competing materials have a significant share and to develop action plans to take market share from them with a material that is in many instances superior in terms of strength, longevity, recyclability, resistance to corrosion and aesthetic splendour.

To encourage more of this type of thing, we present Awards at our Annual Conferences for the Best New Applications for Stainless Steel in two categories: Best New Technology and Best New Development. The aim is to encourage and then to propagate excellence in marketing innovation and dedication. Participation in these Awards Programmes has improved dramatically in the past year, with 7 entries for the Best Technology Award and a very pleasing 33 entries for the Best New Development Award. I am sure that this reflects the increased focus on market development and I hope that this year's entries will inspire even greater efforts in the years ahead. Once again, the standards are remarkably high and exhibit fresh ingenuity. As before, that makes the judges' task very difficult, as is illustrated by the joint winners in some categories.

The range of entries is very varied and in some cases shows a strong trend towards forward thinking. The purpose of these Awards is not only to reward excellence but also to increase market development

by increasing the pool of creative talent. To enable as many of our members as possible to benchmark their own activities against the winning entries, we will continue our practice of publishing all entries in this Brochure. Members are encouraged to read them carefully – there may be an opportunity which can be used in their own markets.

This Awards Programme will continue, because the Awards are valued by the winners. They use them in their own marketing literature. But we hope that this Brochure will encourage increased participation again next year. And don't forget, "you have to be in it to win it".

John Rowe  
Secretary-General  
International Stainless Steel Forum  
Brussels





# Best New Technology Case Studies

## Stainless Steel Bicycle

**Name of member:** Centro Inox  
**Manufacturer:** Design: Tobias Knockaert  
 (Industrial Designer  
 @ Eleventwentyseven,  
 Innovation Engineer  
 @ D'Haene - Brugge,  
 Belgium - dhaene-nv.  
 be, eleventwentyseven.be)  
 Made by: V.A.C. MACHINES  
 nv/sa - Brugge, Belgium  
 - vac-machines.be  
 Employed laser machines:  
 TRUMPF GmbH, trumpf.com

**Field:** transport

**Environment:** urban

**Grade and surface:** EN 1.4301 (AISI 304)

**Advantage point of using stainless steel:**

Resistance to atmospheric corrosion, excellent aesthetic appearance and very good mechanical properties

This application is interesting, not only for the remarkable originality, but for the study and the production process adopted. Using stainless steel to realise a bicycle frame could seem a contradiction, due to the considerable specific weight characterizing this material with respect to other materials such as aluminium, titanium alloys or carbon fibres. However, the total weight is absolutely



Picture courtesy of Centro Inox

“competitive.” The processing involves the laser “drilling” of the stainless steel. This guarantees a sequence of full and empty sections to provide adequate rigidity and robustness. But there’s more! The designer wanted these limited edition bicycles to



Picture courtesy of Centro Inox



Picture courtesy of Centro Inox

be tailor-made for customers. This was allowed by the extreme versatility characterising the stainless steel (in this case EN 1.4301/AISI 304) and the fact it can be specially moulded for an increasingly demanding and elitist public.

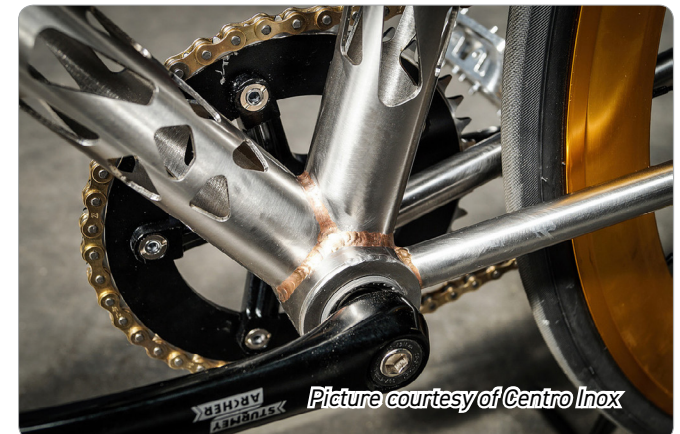

Picture courtesy of Centro Inox

## C 2 Fresh Water

**Name of member:** Columbus Stainless  
**Manufacturer:** Destrilinx PTY (LTD) – Jaco Prinsloo  
**Field:** green energy; water equipment  
**Environment:** marine, urban, rural, coastal, industrial  
**Grade and surface:** austenitic and ferritic stainless steel  
**Advantage point of using stainless steel:** out lasting any other material; Mirror bright finishing 430 stainless steel

C 2 Fresh Water, (patent pending), is an invention that can clean polluted/sea water to a safe potable water without using any filters. It can be used for irrigation purposes, depending on the segments installed in tandem or the quantity of units. The unique way of separating the fresh water is one of the outstanding features. We condense the steam which will be fresh water. This water will be ozonated to ensure that no bacteria can be present in the water. Segments can be added to improve the production to as much as 40 segments per unit which will result in a total length of 100 metres. The solar system will follow the sun by means of an electronic unit. The idea of this invention is to be used without the use of fossil based fuel or any outside energy source, and solely depends on solar energy. In the case of seawater it can produce salt as a by-product. For polluted water, one can recover minerals and



*Picture courtesy of Columbus Stainless*



*Picture courtesy of Columbus Stainless*



*Picture courtesy of Columbus Stainless*



*Picture courtesy of Columbus Stainless*

trace elements on the waste side. It is much more cost effective compared to reverse osmosis systems. This product poses absolute no danger to birds or the environment in comparison with solar farms. Although the plumbing is part of the unit, it does not rotate with the rest of the equipment, which makes this unit unique on its own, with less moving parts. This unit can also be used for fish farms in the process of heating water to the required temperatures.



## Stainless Steel Sheet as used in Turbine Housing [CK-SMiTH]

**Name of member:** NIPPON STEEL Stainless Steel Corporation  
**Manufacturer:** Calsonic Kansei Corp.  
**Field:** automotive  
**Environment:** urban, rural, industrial  
**Grade and surface:** high heat resistant ferritic stainless steel  
**Competing material:** cast iron of carbon steel or austenitic stainless steel

**Advantage point of using stainless steel:**  
**Using thinner sheet material instead of Cast Iron, result in:**

1. Reduced heat capacity
2. Improved heat retention
3. A reduction in total weight, which leads to reduced fuel consumption and an improved performance in exhaust efficiency.

**Reasons to adopt high-heat-resistant ferritic grade;**

1. Higher durability for more than 850 degrees Celsius
2. Less de-formability at high-temperatures

A conventional turbine housing has a comparatively high heat capacity, because it is made of a solid layer of high heat resistant cast iron. Therefore, when the system starts at a cold temperature, it takes a long time until the temperature of the exhaust gas rises to the activation temperature of the purification catalyst system.

Calsonic Kansei Corporation has focused on this issue and has developed a new turbine housing system for diesel engines - "CK-SMiTH", which has replaced conventional cast iron with stainless steel sheet material. The CK-SMiTH has a dual layer structure of thinner press-formed stainless steel sheet materials, to reduce its weight and heat capacity. The reduced heat capacity leads to shorter activation time for the exhaust purification catalyst system from a cold start. In addition, an air layer within this dual structure improves its heat retention, and this high heat retention can extend idling stop time, because heat loss is reduced during engine stoppage. Furthermore, thanks to the reduction in heat loss to external systems, there is an efficiency of the turbine, even after warm up.

Thus, thanks to these advanced characteristics, the CK-SMiTH results in reduced fuel consumption and a higher performance in exhaust efficiency. Given the stringent requirement against environment pollution, turbocharger systems have been, and will continue to be used, to ensure the high performance of diesel engines while reducing their environmental impacts. In addition, the requirement to have high durability at higher exhaust gas temperatures is expected to increase in the future, particularly in the field of gasoline engine systems, and the technology of the CK-SMiTH also can be adopted in high-performance system for gasoline engines.

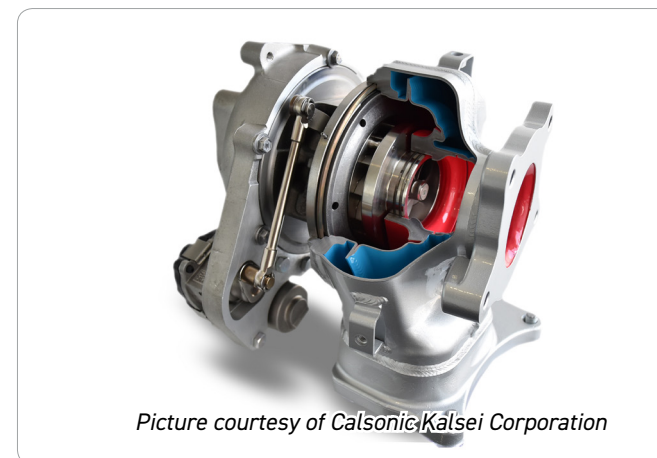

*Picture courtesy of Calsonic Kansei Corporation*

Finally, using thinner press-formed sheet materials in turbocharger systems contribute to the expansion of the stainless steel market, and is also expected to encourage improvements in fabrication technology.





## KAGRA, Large-scale Cryogenic Gravitational-wave Telescope of Japan

**Name of member:** NIPPON STEEL Stainless Steel Corporation

**Owner:** Inter-University Research Institute Corporation High Energy Accelerator Research Organization/KEK; and Institute for Cosmic Ray Research, The University of Tokyo/ICRR

**Field:** scientific observation facility

**Location:** Kamioka Town Hida City Gifu Pref. Japan

**Environment:** indoor; ultra high vacuum cryogenic

**Grade and surface:**

- Hot forged stainless steel round shape for "Recoil Mass"  
Recoil Mass is attached to the controlling device to hold the sapphire mirrors, which are one of the most important parts of the laser interferometer to detect a space-time distortion. Grade: NSSC 130S (18Cr-6Ni-11Mn-0.3N, similar to ASTM A666 XM-11)  
Weight: 200kg x 4 pieces
- Cold rolled stainless steel sheet for welded pipes  
Grade: SUS304, No. 2B finish, 4.5mm thickness  
Weight: Approx. 130 tons
- Stainless steel plate for welded pipes

- Welded stainless steel pipes for ultra-high vacuum duct  
Grade: SUS304L, #150 electro-polishing for inner surface  
Weight: Approx. 600 tons  
Grade: SUS304, #150 electro-polishing for inner surface  
Weight: Approx. 20 tons
- Welded stainless steel pipes for the Cryostat (a vessel whose inside is cryogenic and highly evacuated)  
Grade: SUS304, #150 electro-polishing for inner surface  
Weight: Approx. 60tons  
Total amount of stainless steel from NIPPON STEEL Stainless Steel Corporation Approx. 800 tons.

Advantage point of using stainless steel:  
 ←NSSC130S for "Recoil Mass"→  
 Stable and low magnetic permeability (even after machining) in a cryogenic condition (-253°C)  
 Excellent manufacturability of round shape (340 mm ø x 270 mm L).  
 ←SUS304L and SUS304 for the duct and "Cryostat"→  
 Excellent polishability by reducing inclusions, and rigorous surface inspection

"KAGRA" is the large-scale cryogenic gravitational-wave telescope in Japan, which will start up its observation in 2019 as the third gravitational-wave

detector in the world, following LIGO in the United States and Virgo in Italy.

Approximately 800 tons of NSSC's high-performance austenitic stainless steel is applied to the laser interferometer which is the vital part of KAGRA

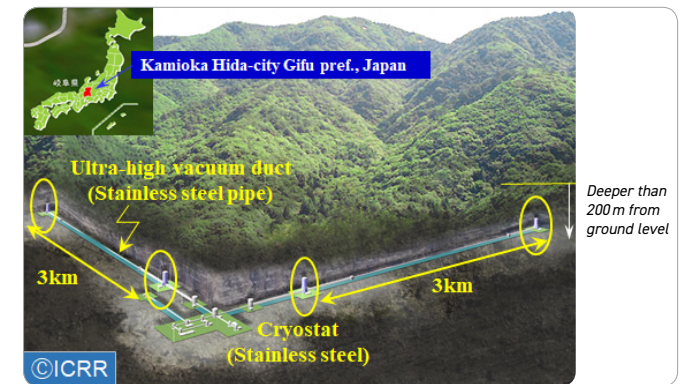

Photo 1: Schematic underground view of KAGRA facility

to detect extremely small space-time distortion occurred by gravitational waves. The laser interferometer is to measure the difference of length of two split laser beams passing the same distance after generated from one source. The two 3,000 meters-long ducts where the two laser beams pass through orthogonally are welded pipes made of SUS304L. It is an ultra-high vacuum condition inside and the air pressure is just



Photo 2: Ultra-high vacuum stainless steel duct of 3,000m in length, as the laser path in the interferometer

1/100,000,000,000 of the atmosphere.

The distortion occurred by gravitational waves can be measured as the difference of the total distance of the two laser beams. The beams are reciprocated for 500 times between the sapphire mirrors installed in cryogenic ultra-high vacuum vessels called "Cryostat" which are located at each end of two ultra-high vacuum ducts. The laser beams run 3,000 kilometers respectively and the difference of the total distance of them is just  $10^{-19}$  m, or 0.0000000000000000001 meters.

NSSC130S\* is used for "Recoil Mass" which holds sapphire mirrors and is attached to the control

device in the extremely cold condition,  $-253^{\circ}\text{C}$ . Several measures have been implemented to eliminate all possible noise which might disturb the detection, because the distortion caused by gravitational waves is just  $10^{-19}$  m when it reaches the earth. KAGRA was installed at least 200m below the ground surface to avoid the influence of noise from the ground. Moreover, it has adopted cutting-edge technology to cool down the sapphire mirrors to cryogenic temperatures ( $-253^{\circ}\text{C}$ ) to reduce thermal noise at the molecular level.

NSSC's stainless steel used in this project has met the tough requirements to support these advanced technologies, including non-magnetic stability in cryogenic temperature.

After the test observation, it is expected that all installation work will be finished soon and KAGRA will start the first scientific observation in late 2019. It has been proved that stainless steel can contribute to the development of the Gravitational-wave astronomy, which was just started to be studied.

\*NSSC130S (YUS130S) was also applied to the collars for dipole magnets of Large Hadron Collider (LHC) of the European Organization for Nuclear Research (CERN), which helped to discover Higgs boson. The discoverers, Prof. François Englert and Prof. Peter W. Higgs, were awarded Nobel Prize in physics in 2013.



Photo 3: Cryostat (as a container for high purity crystal sapphire mirror, and so on)

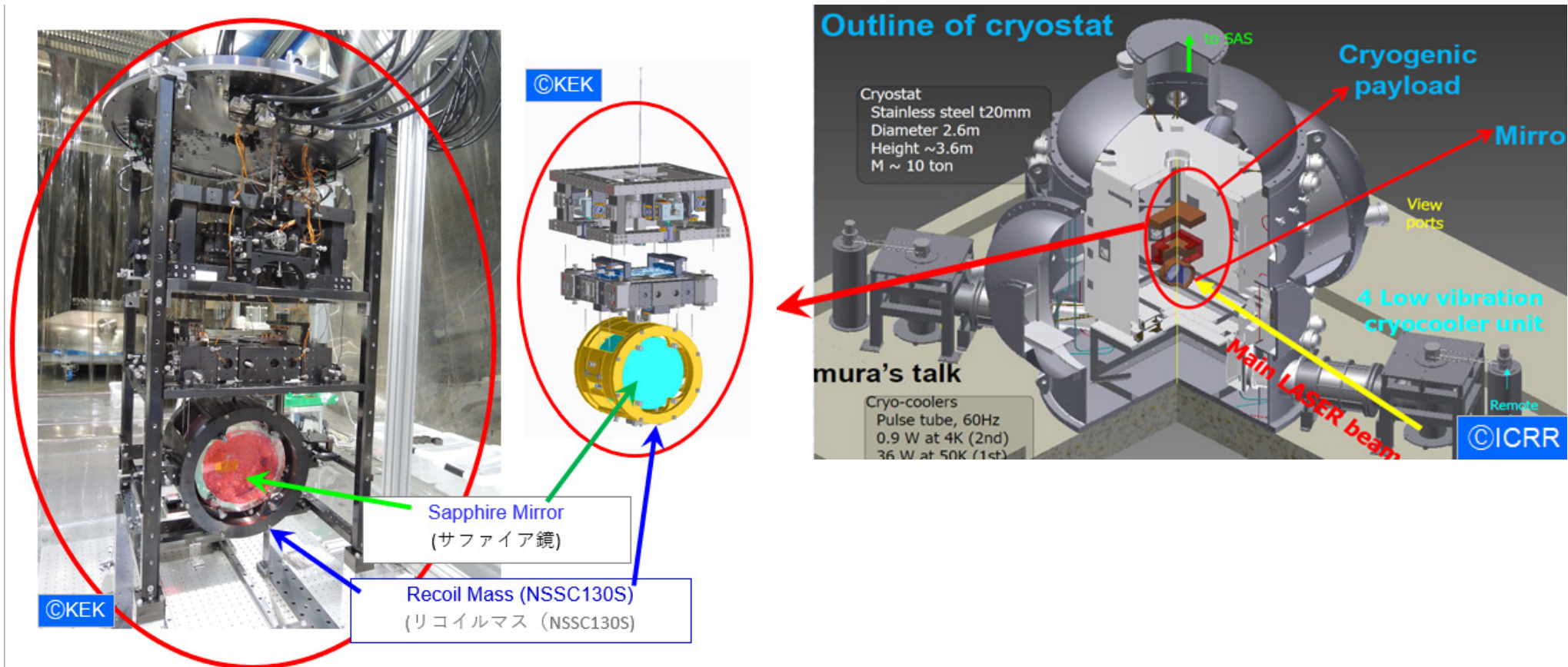

Figure1: Schematic illustration of Cryostat, Sapphire mirror, and its recoil mass made of NSSC®130S.

## Fukuoka Bar Association Hall

**Name of member:** NIPPON STEEL Stainless Steel Corporation

**Manufacturer:** Toyo Stainless Polish Co., Ltd.

**Field:** Sanwa Tajima Corporation Architecture, Building and Construction

**Environment:** urban, coastal

**Grade and surface:** NSSC220M 18 tons and NSSC FW2 2 tons, design polished finish

**Advantage point of using stainless steel:**  
 NSSC220M:  
 Excellent rust-resistance as material for exterior  
 NSSC FW2:  
 Corrosion resistance and silvery-white color after polishing

“Fukuoka Bar Association Hall” is the first building to be constructed in the redevelopment project of the Tenjin Area of Fukuoka City, the largest city in Kyushu District. It is designed by Mr. Koichi Furumori, an architect who lives in Fukuoka, to express the dignity of lawyers and to be approachable for local citizens, located in the same area as the district court and the public prosecutor’s office. The characteristics of this hall are not only the application of cutting-edge technologies for the structure, but was also the design using stainless steel sheet for both the exterior and the interior.



The surface of the stainless steel sheet is polished to express the design derived from the traditional textile pattern “Hakataori Kenjo-gara”. “Hakataori Kenjo-gara” is originated from the Kenjo-gara textile, which was proffered, or “Kenjo”, to the Shogun from Fukuoka in the Edo period. The pattern is a series of alternating lines of stripes and lines which are comprised of rhombuses to express buddhist teachings and flower bowls. It has been common to express Kenjo-gara on buildings with tiles by color differences, but there are no examples to express it with stainless steel. This time, the Furumori Koichi Architectural Design Office, Toyo Stainless Polish Industry Co., Ltd, the expert of stainless steel polishing located in Fukuoka prefecture, and NIPPON STEEL Stainless

Steel Corporation strived to express the Kenjo-gara pattern by changing the type of polishing on the surface of the stainless steel sheet. Toyo Stainless Polish Industry has been especially making its effort to express the appearance which can be seen both as lines from a distance and as rhomboid patterns at a close range. It repeated its trials by applying its technology of complex design polishing and finally achieved the unprecedented finishing of stainless steel.



Because the designer and the owner hoped to adopt products of local companies, NIPPON STEEL Stainless Steel Corporation as a manufacturer who has the production base in Fukuoka, provided



*Picture courtesy of 2019 @MORI KYOKO*

the original stainless steel appropriate to the environment. Although Tenjin area is located close to coast, stainless steel type 304 is frequently used as a material for buildings, and rust can be seen on the surface. Therefore, NIPPON STEEL Stainless Steel Corporation proposed NSSC220M as the exterior of the hall, which has been adopted to several buildings in coastal area due to its excellent rust-resistance. In addition, NSSCFW2, whose polished surface becomes a characteristic silvery-white color which cannot be achieved by other stainless steel grades, is applied

to the interior.

Due to the strong zeal and advanced technologies of local companies, the hall makes local people have familiarity and pride being a citizen of Fukuoka. Moreover, it can be argued that this reflects the potential of stainless steel as material for decoration. To contribute for further development of the stainless steel market, we will continue to expand the application of stainless steel for sophisticated design buildings.

## Folded stainless steels create a new concept in bend-formed body structures for small electrified urban vehicles

**Name of member:** Outokumpu Oy  
**Developer:** Fka Aachen  
**Field:** automotive  
**Location:** Aachen, Germany  
**Environment:** urban  
**Grade and surface:** Temper-rolled austenitic stainless steel

**Competing materials:** Hot-formed ultra-high strength carbon steels and aluminium extrusion profiles

**Advantage point of using stainless steel:**

- Temper-rolled ultra-high strength austenitic stainless steels have been used in an innovative approach to the design of bend and welded body structures for small electrified urban vehicles inspired by folded packing cases.
- The number of individual components and welds in a body-in-white has been halved.
- This approach eliminates the traditional high investment in forming tools as well as providing excellent intrusion withstand and energy absorption behaviour during vehicle crash situations
- Combined with innovative manufacturing processes, stainless steel significantly reduces the CO<sub>2</sub>-footprint of L7e category vehicles and enables local manufacturing on a worldwide basis

Stainless steels are well-known for their excellent formability. But currently, this advantage is used rarely in automotive manufacturing. Now Outokumpu is demonstrating the suitability of temper-rolled austenitic stainless steel with Rp0.2 > 800 MPa for the manufacturing of body structures for the fast-growing sector of small urban electrified vehicles

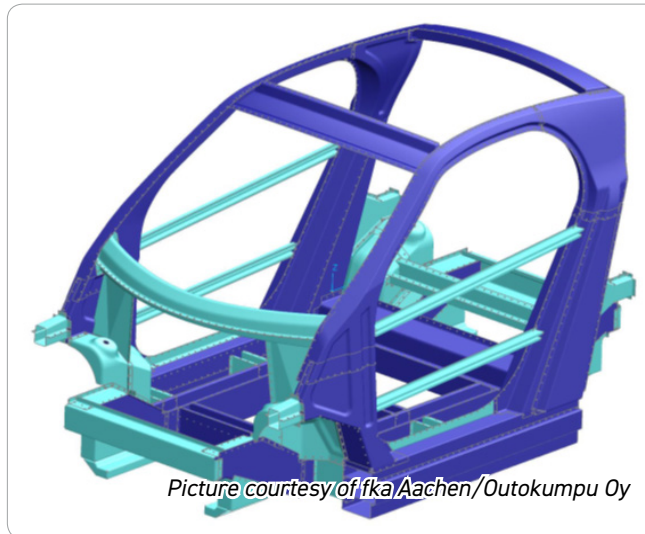

Picture 1: Primarily bend-formed vehicle structure (< 180kg) developed only with austenitic temper-rolled stainless steel in two strength levels (dark blue for base material yield strength level of 800 MPa, lighter blue for yield strength level 500MPa. ©fka Aachen/Outokumpu Oy

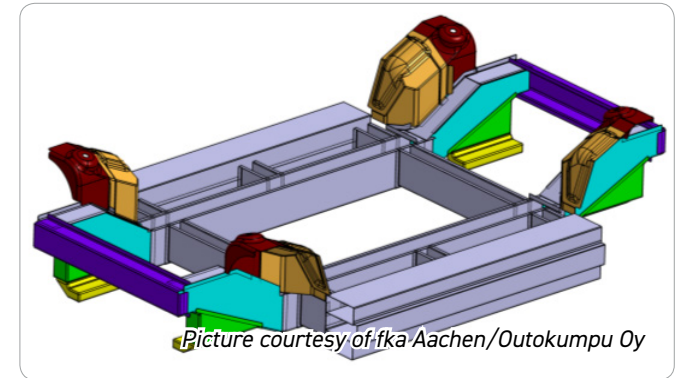

Picture 2: Bend-formed stainless floor structure for safety integration of battery modules, designed as a cost-effective common part strategy ©fka Aachen/Outokumpu Oy

classified by the EU as L7e-vehicles (total vehicle weight < 450 kg without batteries). In this sector, many start-ups and local manufacturers do not have the established manufacturing lines, investment-intensive deep-drawing tools and cost-intensive coating lines that would enable them to compete with the major OEMs. For example, the current state-of-the-art for a body-in-white construction is a steel-intensive design with 600 parts and up to 6,000 spot welds, while forming tools and presses require an investment of up to €2 million per tool. L7e-vehicles are not only a significant challenge for lightweight design but also for crash safety.

Currently, there are no vehicles in this category that meet the official crash requirements of M1-category vehicles like Smart or VW Golf.

To eliminate the drawbacks of the traditional

approach, the advantages of temper-rolled ultra-high strength austenitic stainless steels have been utilized with a new design methodology for vehicle structures inspired by folded packing cases. The manufacturing steps for the floor structure and parts of the pillars require only tool-less bend-forming and one welding procedure to create a folded and therefore stiff lower vehicle structure. The material properties combine with the folding principle to halve the number of individual components and welds. This results in a much lighter structure (less than 180 kg) with increased crash safety that is constructed by more simple, cost-effective manufacturing processes with shorter cycle times as well as lower CO<sub>2</sub>-emissions over the whole vehicle lifetime.

Advantages:

- Compared with other high-strength but less ductile materials, ultra-high strength austenitic temper-rolled stainless steels enable cost-effective manufacturing of a stiff vehicle structure with tool-less bend-forming and no need for coating processes
- The designed safety cell has enabled the construction of a L7e-vehicle to meet the pole side impact requirements of M1-category vehicles such as Smart and VW Golf
- The number of body-in-white components and spot welds has been halved against current state-of-the-art vehicles yielding significant cost-reductions and faster manufacturing
- Minor intrusions into battery compartment during pole side impact
- Torsional stiffness at the same level as series vehicles
- Leveraging the benefits of additive manufacturing and aluminum profiles, this concept demonstrate that folded stainless steels can play a key role in reducing weight as well as enhancing safety and stiffness

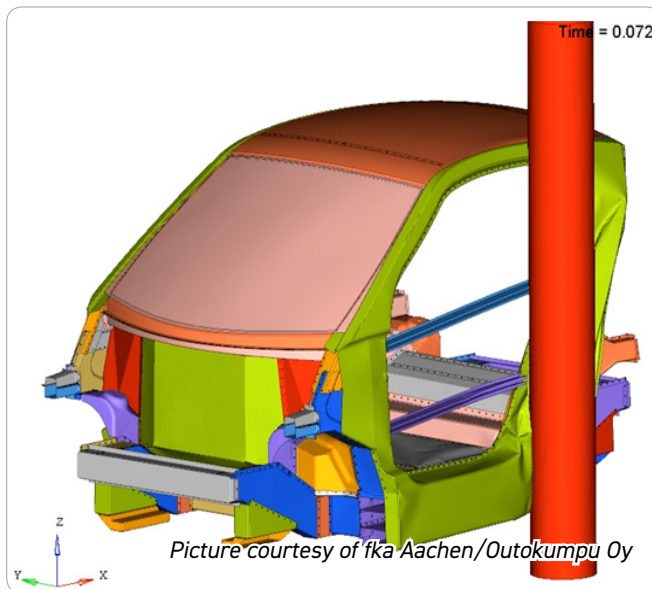

Picture 3: Successful withstand during crash simulation of the primarily bend-formed stainless vehicle according to EuroNCAP lateral side impact. ©fka Aachen/Outokumpu Oy

## Ferritic stainless steel with enhanced formability for exhaust systems of hybrid and plug-in hybrid vehicles

**Name of member:** POSCO  
**Manufacturer:** Sejong  
**Field:** automotive, transport  
**Location:** Korea, China, EU, USA  
**Environment:** urban, rural, industrial  
**Grade and surface:** STS439 (Poss439XF) / 2B  
**Competing material:** austenitic stainless steel  
**Advantage point of using stainless steel:**  
 The complex and compact exhaust parts of increasing eco-friendly hybrid and plug-in hybrid vehicles in the near term can be fabricated by virtue of excellent formability of the developed ferritic grade.

Governments around the world are seeking ways to reduce oil use and green gas emissions by strengthening regulatory efficiency standards. Automotive companies are deploying various passenger vehicles with advanced internal combustion engines and fuel-efficient hybrid powertrains to meet lower emission levels. The hybrid powertrains normally consist of an efficient combustion engine and an electric driving unit of motors and battery modules. Since two driving units are installed on a vehicle, the spaces for exhaust parts are going to be limited and the shapes of exhaust parts of hybrid vehicles tend to be compact and complex. Moreover, the demand of lightweight exhaust parts guaranteeing longer

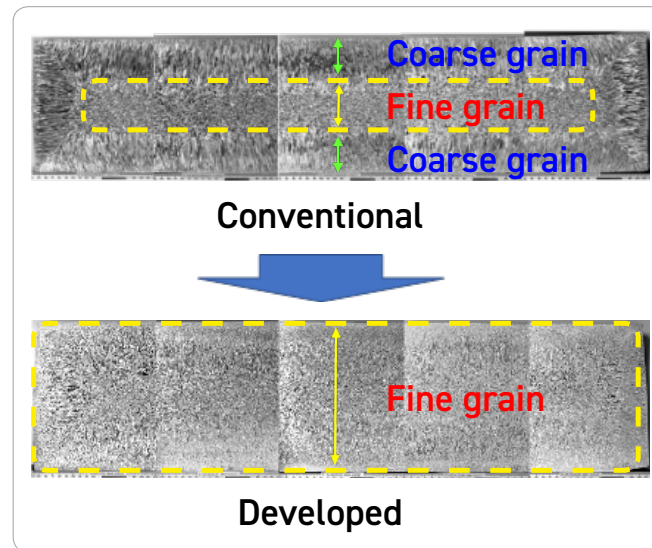

Figure 1: Comparison of conventional and developed slab grain structures  
 Picture courtesy of POSCO

lifetime would result in the selection of high chromium stainless steel as a preferred material. POSCO has developed the cutting edge fabrication technology over the years to maximize the formability of high chromium content ferritic stainless steels. By developing innovative oxide-metallurgy technologies during the steel making process and advanced texture-control engineering, extra formable ferritic stainless steel has been

commercialized. The controlled equiaxed grain structure in slabs is one of outstanding technical achievements, which is the prerequisite to make extra formable materials. The refinement of grain structures in slabs by the oxide-metallurgy can be achieved even without the usage of EMS (Electro Magnetic Stirrer) in continuous casting and this could reduce the investment cost of construction of new manufacturing facilities. The deep drawing property of the developed material is elevated 20~30% higher than conventional ferritic grades. The 180 degree bending of pipes made with conventional and new developed ferritic stainless steels show clearly the benefit of the enhanced formability. The wrinkling defect during bending is diminished by adopting the developed material. The

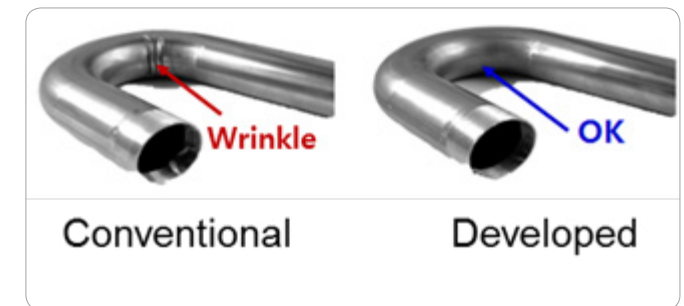

Figure 2: Pipe bending with conventional and developed ferritic stainless steels  
 Picture courtesy of POSCO



deep drawing stamping of muffler caps in exhaust parts of a compact-sized vehicle demonstrates that necking fracture by thickness reduction in the deformed part is reduced negligibly as a result of the excellent formability. In addition, more uniform thickness distribution in the deformed part allows to

make it thinner and lightweight. The other distinguished property of the developed material is the excellent mechanical toughness in the welding zone. The TIG welded zone of the developed material shows finer grain structures than conventional ferritic grades. This contributes to the improvement of ductility in the welded zone and then reduces cracks and tearing near the welded zone in the subsequent forming operations after welding. Lastly, enhanced formability can be further utilized in deep drawing applications in other industries.

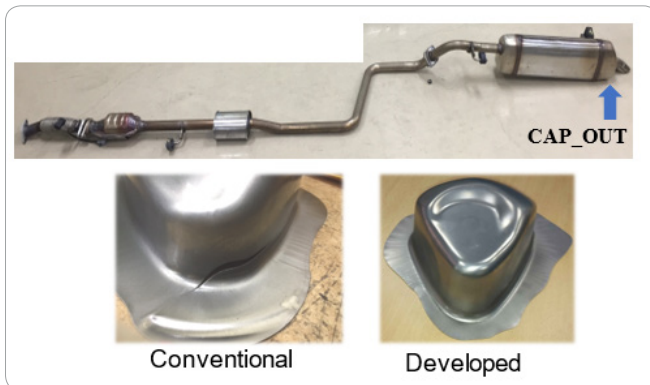
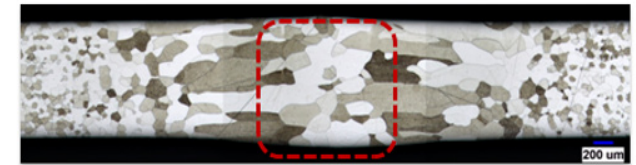

Figure 3: Stamping trials of muffler caps with conventional and developed ferritic stainless steels  
Picture courtesy of POSCO

## Conventional



## Developed

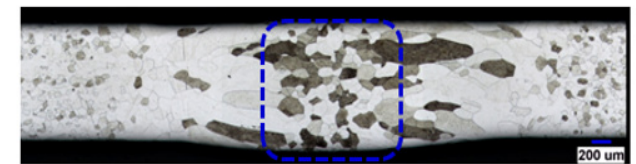

Figure 4: Comparison of weld-zone grain structures between conventional and developed ferritic stainless steels  
Picture courtesy of POSCO





# Best New Development Case Studies

## Extension of Monaco to the Sea

**Name of member:** Acerinox  
**Manufacturer:** Roldan-Acerinox Group  
**Field:** Architecture, building and construction  
**Location:** Monaco  
**Environment:** Marine, coastal  
**Grade and surface:** Duplex stainless steel rebar 1.4362  
**Competing materials:** Carbon steel rebar, epoxy, galvanized steel

**Advantage point of using stainless steel:** Stainless steel rebar ensures high durability and becomes the cheapest option in the long term. It is also a recyclable material with minimum impact to the environment, something that was a must in this specific project.

The reinforcement with stainless steel is located in the external zone of the pillars that face sea water and between the walls of the first hollow part of the caissons, through which sea water enters and circulates freely. Concrete covers the most external stainless steel reinforcements, close to the surface in contact with sea water, with a 100 year durability guarantee in the project.

Last July 2018, began the transfer of the first concrete caisson reinforced with stainless steel rebars, which was towed from its construction site, in the maritime port of Marseille, and finally installed on its site, for the offshore extension of Anse du



Picture 1: extension of Monaco project

portier, in Monaco. This was the first of 18 huge concrete caissons, which with a length of 30 m, 24 m in height, and a unit weight of 10,000 tons, will form the barrier of protection against the sea for the new extension of 6.5 hectares of the new district of the city, which will lead to the construction of 60,000 m<sup>2</sup> of new luxury homes, shops, a park and other public facilities.

The Principality of Monaco currently occupies a space of 195 hectares (approximately 2 Km<sup>2</sup>), of which 20% corresponds to land reclaimed from the sea in the last decades, and this new extension of the Anse du portier district, with an estimated cost of 2000 Million euros will allow its new growth.

The important maritime infrastructure project is developed by the prestigious French construction company Bouygues Travaux publics. The current phases of the Project, corresponding to the submerged infrastructures, will take place until 2020, and then the construction of buildings will proceed until 2025.

These enormous caissons are manufactured in the "Marco Polo", floating construction dock 50m wide, and 27 m high, built in the Polish shipyard Crist of Gdank, under design of Bouygues TP. An area of 10,000 m<sup>2</sup> was prepared for the construction of the concrete caissons inside the maritime port of Marseille. The transfer of the first caissons was completed during the month of October 2018, and they were then loaded with solid materials to ensure

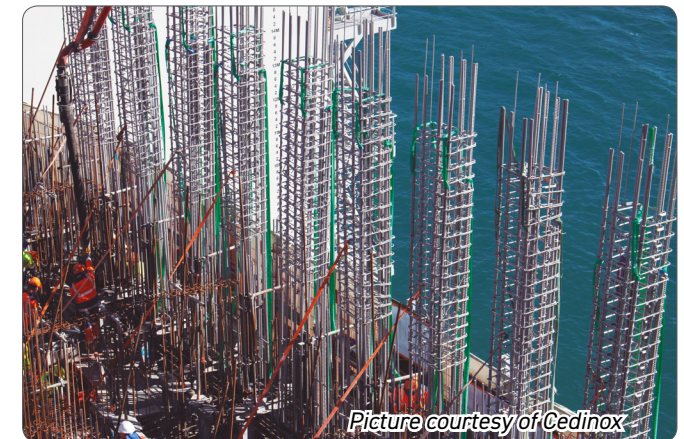

Picture 2: Rebar pillars



*Picture courtesy of Cedinox*

*Picture 3: Rebar encapsuled in concrete*



*Picture courtesy of Bouygues tp*

*Picture 4: inside view of an unfinished caisson*



*Picture courtesy of Bouygues tp*

*Picture 5: Caisson being positioned in the sea*

their stability in the final location. For the construction of the stainless reinforcements, manufactured by the French-Spanish company Sendin and assembled in Marseille by their own workers, more than 4000 tons of stainless steel rebars, RDN 915-EN 1.4362 AISI 32304 duplex

type, have been used, with diameters between 12 and 40 mm, supplied by the company Roldan S.A. , belonging to the Acerinox group, from its Ponferrada (León) plant in Spain. This type of stainless steel with high resistance to corrosion against sea water chlorides, which

eventually will penetrate the concrete by capillarity reaching the reinforcements, will provide long durability of these infrastructures, without presenting deterioration due to problems of corrosion, avoiding costly maintenance costs in the future.



## Stainless steel in rehabilitation of historical heritage

Name of member: Acerinox  
 Manufacturer: Roldan - Acerinox Group  
 Field: Architecture, building and construction  
 Location: Seville, Spain  
 Environment: Urban, rural  
 Grade and surface: Duplex stainless steel rebar

Competing material: Carbon Steel rebar  
 Advantage point of using stainless steel: Stainless steel ensures durability and resistance to humidity conditions over time. It is also compatible to most of the construction materials used in historical heritage buildings.

Restoration and rehabilitation means a huge market for stainless steel. Ancient buildings suffer over time and in many cases must be restored. Most of the ancient materials used are porous so that they cannot be restored with carbon steel. Stainless steel provides a long lasting solution for historical heritage restoration. Due to its excellent properties, assures long durability and fewer interventions. Stainless steel can be used in many forms in this application, for instance as rebar, mesh, angles... among many others. Stainless steel is a perfect example of how a new material can take care of an ancient one.



## Urban waste sorting/recovery container

Name of member: Acerinox  
 Manufacturer: Porras Guadiana Architects  
 Field: Art and street furniture  
 Location: Madrid, Spain  
 Environment: Urban  
 Grade and surface: AISI 316 Finish No1  
 Competing materials: Galvanized steel or plastics

Advantage point of using stainless steel:  
 Stainless steel was the perfect solution for the research, in which very strict functional aspects were combined, related to accessibility, vandal-proof security, waterproofing, legibility and the symbolic nature of the message to be communicated.

This kind of developments enhances stainless steel sustainability, being not only sustainable itself but also contributing to sustainable applications in order to preserve our environment. The application creates a new market for stainless steel and gives solutions to the multiple problems that waste containers can suffer, stressing the idea that waste can and must be sorted and recovered.

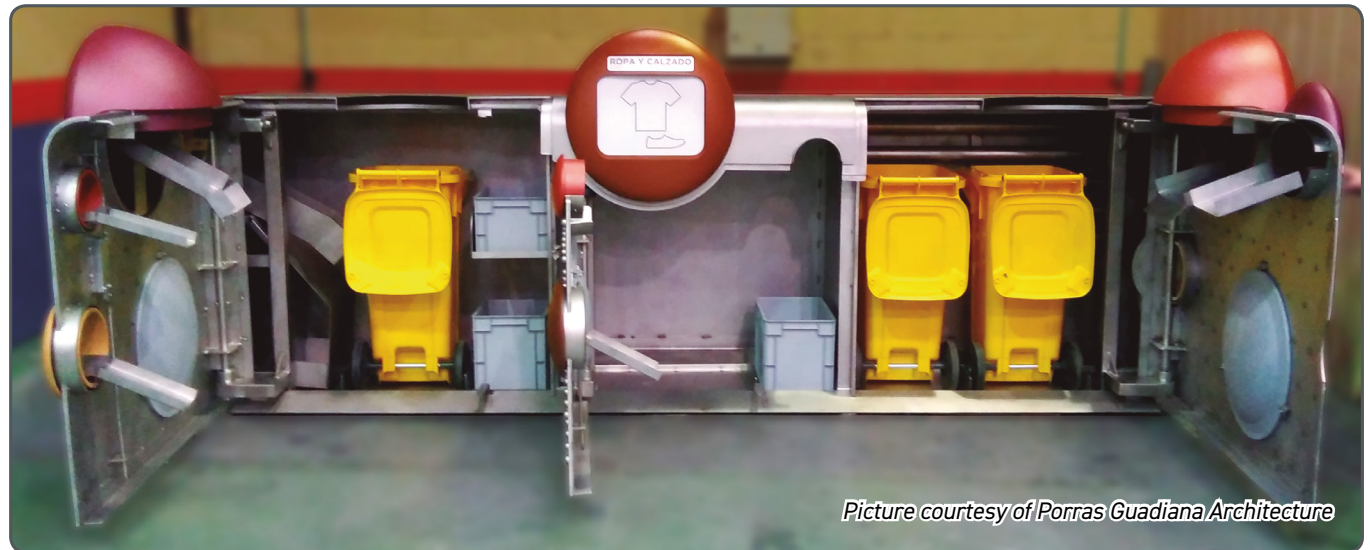

Picture courtesy of Porras Guadiana Architecture

Waste sorting back



Picture courtesy of Porras Guadiana Architecture

Waste sorting front



Picture courtesy of Porras Guadiana Architecture

Waste sorting



## Martensitic Stainless Steel for Knife Blades and Cutting Tools

Name of member: Aperam  
Field: cookware, hollowware and cutlery; food and beverage  
Environment: indoor  
Grade and surface: MA5 (Martensitic Grade)  
t 0.4~6.0 mm

Competing materials: Carbon steel, Ceramic

Advantage point of using stainless steel:

- High degree of hardness
- Improved resistance to corrosion

Thanks to their high-degree of hardness, martensitic stainless steels guarantee a good cutting edge. However, to get this level of hardness requires the use of a high level of carbon content – a content that depletes chromium carbides during heat treatment and thus leaves the stainless steel more susceptible to corrosion. Although the corrosion resistance of high carbon grades can be improved by adding molybdenum, doing so is extremely expensive. As an alternative, Aperam introduces its nitrogen-infused MA5 grade. Not only does nitrogen offer the hardness advantage of carbon, when combined with an increase in chromium content, it also improves corrosion resistance – without the need to add molybdenum. Because MA5 offers a high degree of hardness and improved resistance to corrosion, it has been quickly embraced by the cutlery and kitchen utensils market, who regularly uses it in manufacturing knife blades and other cutting tools.



Picture sourced from Fotolia.



## Stainless Steel Floor for Garbage Truck Hoppers

- Name of member: Aperam  
 Manufacturer: Usimeca  
 Field: industrial machinery and equipment; transport
- Location: Rio de Janeiro, Brazil  
 Environment: urban, industrial, indoor  
 Grade and surface: 410 / #1  
 Competing material: carbon steel
- Advantage point of using stainless steel:
- Improvement hopper's service life threefold
  - High resistance to corrosion limiting the risk for unsanitary and potentially hazardous leakage

In the busy urban areas of Brazil, garbage trucks pick up a lot of trash – keeping the streets clean and the cities sanitary. However, due to the corrosive nature of the waste being collected, over time it begins to eat away at the hopper's carbon steel floor. As this corrosion increases, so does the risk for unsanitary and potentially hazardous leakage. Aperam's solution: stainless steel. A floor made of stainless steel type 410 increases a hopper's service life threefold, making sure the garbage stays inside where it belongs. As an added bonus, Aperam's stainless steel solution is environmentally friendly.



## Concrete Mixer Truck

- Name of member: Aperam  
 Manufacturer: Convicta  
 Field: industrial machinery and equipment  
 Location: Brazil  
 Environment: urban, industrial  
 Grade and surface: 410 / #1  
 Competing material: carbon steel  
 Advantage point of using stainless steel:
- Lifespan improvement (X3.5 times compared to carbon steel)
  - Capacity increase (thanks to a thinner skin of the mixer)

Concrete is a highly abrasive material. In wet environments, the wear becomes much worse, due to the corrosion. Sent spinning around in a cement mixer and it's easy to see why these trucks have a relatively short lifespan. To improve the lifespan of these trucks, Aperam introduces the world's first stainless steel concrete mixer. After demonstrating that the use of stainless steel D410 internal cut pads could double the capacity of existing steel pads, Aperam went one step further and made an entire mixer bowl out of stainless steel. The use of stainless steel gives the mixer a thinner skin, thus significantly increasing its capacity. Furthermore, thanks to stainless steels' high resistance to corrosion, the average lifespan of a cement mixer is expected to be three to four times longer than today's steel models.



*Picture courtesy of Aperam*



*Picture courtesy of Aperam*



## Stainless steel electrical enclosures

**Name of member:** ASSDA  
**Manufacturer:** B&R Enclosures (with material supplied by Outokumpu)  
**Field:** electrical machinery and equipment, industrial machinery and equipment  
**Location:** BHP's Olympic Dam (mining site), South Australia  
**Environment:** industrial  
**Grade and surface:** Grade 316 with a No.4 finish  
**Competing materials:** Zinc coated steel, aluminium

**Advantage point of using stainless steel:** Underground communication networks are a critical link between operations below ground and at the surface to ensure efficiencies in production and personnel safety. Protecting the equipment that delivers these communication networks is vital and stainless steel offers the durability and longevity required to deliver a robust structure to ensure preservation of the internal hardware. In addition, grade 316 offers excellent corrosion resistance, particularly to pitting corrosion which can occur in inland Australia due to high salinity in the ground water.

The electrical enclosures for BHP's Olympic Dam were custom-designed for the client and is now a standard specification for future installations at this site. Electrical enclosures are used across various industries, from mining, oil and gas to industrial and commercial buildings. Many other materials are used – aluminium and zinc coated steel for example – however stainless steel offers a more cost-effective, durable and long-term solution, and aesthetic appeal depending on the application. Stainless steel will always perform regardless of the application in which the enclosure used. This is a good opportunity for materials substitution, promoting stainless steel as the material of choice and delivering positive results for market growth.





## Stainless Steel for Hard Disk Drive (HDD) Cover

**Name of member:** Bahru Stainless  
**Manufacturer:** HOSHIN KENZI(S) PTE LTD  
**Field:** Hard Disk Drive Parts, Components, Electric Appliances, Precision Components and Automotive

**Environment:** indoor  
**Grade and surface:** SUS304, SUS430, SUS420  
**Competing materials:** aluminium, plastic  
**Advantage point of using stainless steel:**

1. Stainless steel is strong and resistant to corrosion
2. Aids in contamination control of the HDD
3. Affordable pricing

Hoshin Kenzi supplies stainless steel of grade SUS 304, SUS 430 and SUS 420 to Western Digital, Seagate and Toshiba for manufacturing of the Covers



Picture courtesy of Hoshin Kenzi(s)

and other Components parts for Mechanical Hard Disk Drives (HDDs).

- 3 Main Global Keys HDD manufacturers are Seagate, Western Digital and Toshiba
- In the recent years, “Clouds Storage” have become inevitable; and Data Storage Centres are expanding and being built in different parts of the world, the quest of Higher Capacity of HDD Storage has instigated for new challenges to Data Storage technology.
- HDD Storage of usual less than 8TB has tremendously grown to the present increase in demand of 10TB, and working towards next level of 15-16TB.
- Stainless Steel with superior characteristics over other metals and materials, it is the best material to use to form Covers for the HDDs and other precision parts of the mechanism for the HDDs.

## Stainless steel floors for bumper cars

**Name of member:** Centro Inox  
**Manufacturer:** I.E.Park S.r.l. SOLI  
 BUMPER CARS -  
 via Don P.Borghi  
 3 - I-42043 Gattatico -  
 Reggio Emilia - Italy.  
 Tel. +39.0522.1678695 -  
 info@iepark.com -  
 iepark.com

**Field:** other  
**Location:** Dubai, UAE  
**Environment:** indoor  
**Grade and surface:** EN 1.4401 (AISI 316), 2B  
 finish

**Advantage point of using stainless steel:**  
 Wear resistance, good mechanical properties at  
 low temperature

There are many uses of stainless steel in the public space: both in Europe and outside of Europe it is now used in all kinds of spaces. The application shown here is interesting, innovative and very original. The floor is made from stainless steel sheet EN 1.4401 (AISI 316) with a 2B finish and a thickness of 3.5 mm, to give good consistency and good resistance to wear. An Italian company has created a new special project within SNOW PARKS: it is the classic "bumper car" model FPU-FLOOR PICK UP SYSTEM, in a version with a fully electrified floor with direct current. Given the particular location, the materials were asked to have good mechanical properties at temperatures of at least -10°C.



*Picture courtesy of Centro Inox*



*Picture courtesy of Centro Inox*



*Picture courtesy of Centro Inox*

## Stainless Steel Power Pack

Name of member: Centro Inox  
 Manufacturer: Hitachi Rail Italy Spa –  
 Via Argine 425 – I-80147  
 Naples – Italy  
[italy.hitachirail.com](http://italy.hitachirail.com)

Field: transport  
 Grade and surface: EN 1.4404 (AISI 316L),  
 externally painted with  
 epoxy paint

Advantage point of using stainless steel:  
 Resistance to atmospheric corrosion, excellent  
 workability and reduced need for maintenance

A new regional transport train called “Rock” has  
 been designed and built by Hitachi Rail Italy for



Trenitalia. The double-floor electric train minimises consumption and has been designed to group all converter units (which transform the continuous 3000 volts current into alternating power), into an “above carbody” assembly. This Power Pack structure built using Centro Inox technical advice was made using EN 1.4404 (AISI 316L) stainless steel in sheets and a welded tube with rectangular section. This structure has a dimension of 5000x2020x630 mm and weighs 1250 kg. Each train, which normally consists of 4 to 5 coaches, has two Power Packs installed – one positioned at the top of the train and the other at the rear. The stainless steel choice was motivated by the fact that it can simultaneously guarantee a material with excellent workability characteristics, reduced need for maintenance and resistance against corrosion.



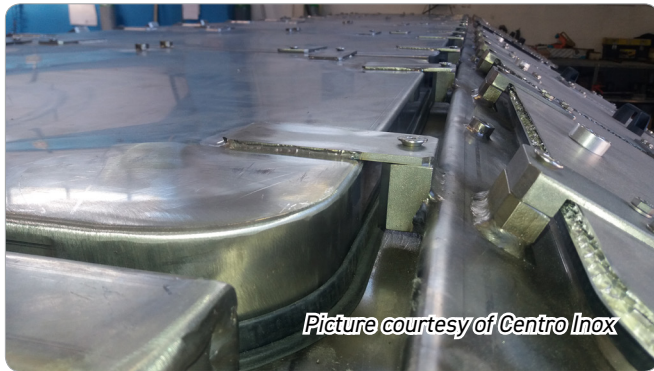

*Picture courtesy of Centro Inox*



*Picture courtesy of Centro Inox*

## Brescia metro stations

**Name of member:** Centro Inox  
**Manufacturer:** Steel Color S.p.A. - via per Pieve Terzagni 15 - I-26033 Pescarolo ed Uniti - Cremona - Italy  
 Tel. +39.0372.834311  
 info@steelcolor.it, steelcolor.it

**Field:** architecture, building and construction

**Location:** Brescia, Italy

**Environment:** urban, indoor

**Grade and surface:** EN 1.4301 (AISI 304), various surface finishes

**Advantage point of using stainless steel:** Resistance to atmospheric corrosion, excellent aesthetic appearance

The Brescia metro was designed to connect the northern districts of the city with those of the southeast area, through the centre, and stainless steel has been used in the construction of the various stations. These stations are the result of a project with both functional and aesthetic connotations, envisaged by Brescia Infrastrutture, aimed at unifying their shape, both for the design and for the choice of materials. Stainless steel EN 1.4301 (AISI 304), in the form of 1 mm thick sheets and with various surface finishes, was widely used. For some types of infill walls, composite panels were used

which consist of a coupling between an external "skin" of stainless steel sheet (with thicknesses varying from 0.5 to 0.8 mm) and aluminium honeycomb. Using this technique, excellent flatness

and a typical stiffness of the composite materials was obtained.

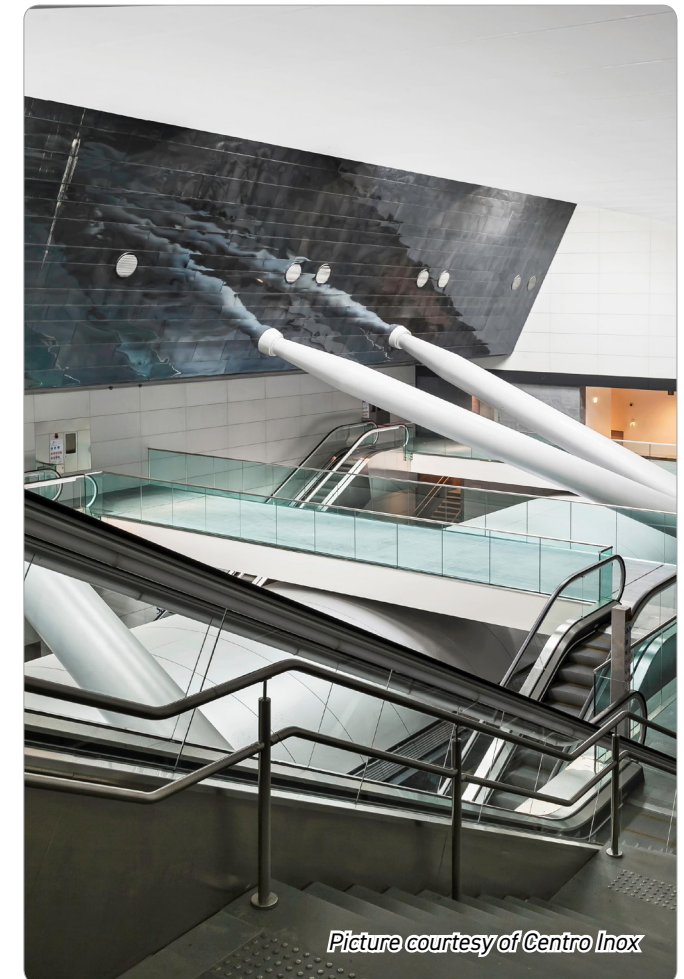





*Picture courtesy of Centro Inox*

## Exhaust Gas Recirculation (EGR) Pre-Cooler

**Name of member:** Columbus Stainless  
**Manufacturer:** Senior Flexonics  
**Field:** automotive  
**Location:** Cape Town, South Africa  
**Environment:** urban, rural  
**Grade and surface:** 304, 309, 321, 316Ti, Inconel 625

**Advantage point of using stainless steel:** Stainless steel has the perfect balance of temperature and corrosion resistance to handle high temperature exhaust gases and water contact simultaneously. Its high ductility allows it to be easily formed and bent into complex geometry.

In internal combustion engines, exhaust gas recirculation (EGR) is a nitrogen oxide (NOx) emissions reduction technique used in petrol/gasoline, diesel and hybrid engines. It also increases efficiency giving better fuel consumption. An EGR cooler lowers the temperature of exhaust gases recirculated by the EGR and thereby decreases the NOx emissions. Senior Flexonics from Cape Town, South Africa worked in collaboration with Senior Flexonics from Crumlin, Wales to design and develop an EGR cooler product and assembly process. The product design was mainly done in Wales and Cape Town focussed on manufacturing the design and the fabrication process. The manufacturing process is possible through a Vacuum Brazing technology being used by Senior Flexonics Cape Town.



These routable co-axial heat exchangers can be used as water cooled charged air coolers or as additional and primary EGR coolers. The target market for this cooler is the passenger vehicle and On/Off Highway vehicles.

- **Product:** The cooler is a light weight stainless steel tube-in-tube design with excellent thermal loading characteristics.
- **Design:** The patented design is simple, compact, routable and cost effective to manufacture. It cools recirculating gasses by up to 150°C through a finned tube length of 100 mm.
- **Manufacture:** The cooler is assembled and

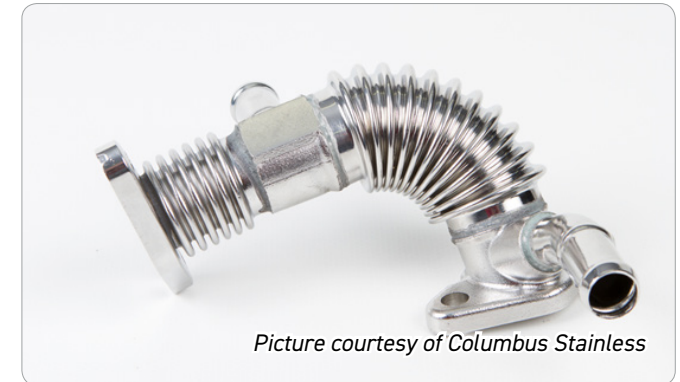

vacuum brazed in Senior Flexonics Cape Town. It consists of stainless steel and Inconel castings, spigots, bellows, tubes and flanges and is Nickel brazed.

Gas Tin	Gas flow rate	Gas P-drop	Effective-ness	Gas Tout	Coolant Tin	Coolant flow rate
°C	kg/min	mbar	%	°C	°C	L/min
600	1	32.8	21.1	477.9	19.9	9

Copyright Columbus Stainless

\*typical cooler functionality

This cooler design cannot be manufactured from any other material at a competitive cost and still maintain functionality.

Stainless steel is formed in a variety of different

ways to manufacture the components for these cooler assemblies. This design therefore supports the stainless steel market by making use of components sourced locally and globally from a variety of companies that melt and cast, fabricate, form, cut, heat treat and finish stainless steel. The components vary in nature and geometry and come together seamlessly to create a leak-tight brazed cooler. In the local market these coolers support the market

for thin-gauge stainless steel (from Columbus Stainless (Pty) Ltd), which historically have been used mainly for the manufacture of flexible decouplers. It therefore diversifies the use of thin-gauge stainless steel locally and ensures a more promising future. Globally it supports the market for stainless steel castings, spigots and flanges, with the castings designed to be replaceable by stainless steel 3D printed components in future.



*Picture courtesy of Columbus Stainless*

## Leisure and Commercial Hardtop Storage Solutions

Name of member:	Columbus Stainless and SASSDA
Manufacturer:	RSI SMARTCANOPY® (Rock Solid Industries)
Field:	automotive, transport
Location:	Pietermartizburg and Durban, South Africa
Environment:	urban, rural, coastal, industrial
Grade and surface:	409
Competing materials:	aluminum, fiber glass, plastic
Advantage point of using stainless steel:	
1.)	Superior strength to weight ratio
2.)	Weldability
3.)	Material springback
4.)	Superior Life Cycle Costing
5.)	Paintability

Grade 409 stainless steel featured throughout their entire SmartCanopy range, Rock Solid Industries (RSI) uses Life Cycle Costings (LCC) to effectively educate and demonstrate to their customers the advantages of stainless steel.

Catering to a wide range of industries which includes specialised commercial fleets, RSI's advances in product design and manufacturing techniques have led to the development of strengthened products with a reduced weight, growing their product offering to compete with traditional fiberglass and aluminium canopy manufacturers.



Picture courtesy of SASSDA

RSI Hearse Canopies

Their SmartCanopy range features a modular design that comprises just five main parts that are bolted together into a patented design. Easy to assemble and with replaceable parts, it offers a complete knock-down flat pack solution which is already revolutionising the canopy industry. Meeting the ISO 9001:2015 and TUV Certified requirements, advances in their latest TUV specifications include solid side panels (complete



Picture courtesy of SASSDA

RSI Commercial Canopies



Picture courtesy of SASSDA

RSI Leisure Canopies

sleeve) which have reduced the weight and strengthened the overall canopy structure. Eco-friendly with a comprehensive warranty and



Picture courtesy of SASSDA

RSI LWB Dropsides

reduced logistical costs, the SmartCanopy range is set to take on the fibreglass market aggressively with the launch of their latest SmartCanopy Evo design, which is 100% recyclable, offers improved



Picture courtesy of SASSDA

RSI One Ton Contractors

functionality and has the benefits of their TUV spec, and has been made possible through new technology in sheet metal forming which RSI has recently invested in.

**Sassda Awards Judges' Comments:**

For offering sustained high-quality and customised services to the transport industry for many



Picture courtesy of SASSDA

RSI Toolbox Canopies

years, this industry leader is a highly competent manufacturing business with the management team in sync and in close contact with the product and employees.

## NDF 250-man Mobile Kitchen

Name of member: Columbus Stainless and SASSDA

Manufacturer: Desert Wolf Consulting

Field: food and beverage

Location: Pretoria, South Africa

Environment: rural

Grade and surface: 304

Advantage point of using stainless steel:

The development of this product has ensured that LPG can be eliminated. (LPG cannot be flown and has limited availability in remote areas and has huge safety risks.) Smokeless diesel cooking is now possible with an enhanced work flow design. In addition, the mobile kitchen is a smart kitchen, being powered by a tablet which seamlessly links planned menu's with ingredient orders from the army stores. Integrating this unique BOMA stainless steel oven and stove on the legendary Desert Wolf 3CR12 chassis gave Namibian defence a new capability – rugged mobile 4x4 mobile kitchen on a trailer.

A reputation for creating some of the world's toughest off-road trailers, manufacturer and exporter Desert Wolf Consulting is a preferred supplier to the South African National Defence Force for its diesel cooking burning technology. Its Boma 250-man Field Kitchen is a tour-de-force. With its unique design, together with its significant stainless-steel component, the development of their smokeless diesel burners has allowed portable kitchens to be



independent of difficult to access LPG gas supplies. With no diesel stoves with the required capability available on the market at the time, the rugged Desert Wolf BOMA 250 - man 4x4 mobile – and smart kitchen – was born.

Powered by a tablet, it seamlessly links planned menus with ingredient orders from the army stores and provides for a range of menus. Burning cleanly with no smoke emissions, its unique design allows two chefs to stand opposite each other rather than



Picture courtesy of SASSDA

side by side, resulting in better work flow with access to the oven and frying surface. Its diesel fired technology is now being implemented in the new SANDF 50 and 200-man containerised field kitchens will form the heart of military kitchens featuring uniquely South African designed technology.

**Sassda Awards Judges' Comments**

For designing a brilliant, novel, mobile bush catering solution, using only diesel, and utilising sophisticated 4th Industrial Revolution technology.



Picture courtesy of SASSDA



Picture courtesy of SASSDA



Picture courtesy of SASSDA



Picture courtesy of SASSDA

## FRACTAL Stainless Steel Tiles

**Name of member:** IMINOX  
**Manufacturer:** Outokumpu Mexinox  
**Field:** Architecture, building and construction  
**Location:** Different cities of Mexico. San Luis Potosí, SLP and Guadalajara, Jal.

**Environment:** Indoor  
**Grade and surface:** 430 P4 Tickness Gauge 24 (0.61 mm)

**Competing material:** Ceramics  
**Advantage point of using stainless steel:**

- Esthetic
- Durability
- Innovation
- Creativity
- Modernity

FRACTAL stainless steel tiles create new market because of two reasons:

1. FRACTAL is presented as a “do-it-yourself” product, a feature that is not common used for tiles to cover walls.
2. FRACTAL generates creativity of the end user since all the tiles of the system are identical, however depending on the direction of polishing (vertical or horizontal) acquire two different tonalities with which you can “play” to create custom designs. Fractal is a fun product to cover walls using the creativity of the end user.



*Picture courtesy of IMINOX/  
Fernando Correa Carrillo*



*Picture courtesy of IMINOX/  
Fernando Correa Carrillo*

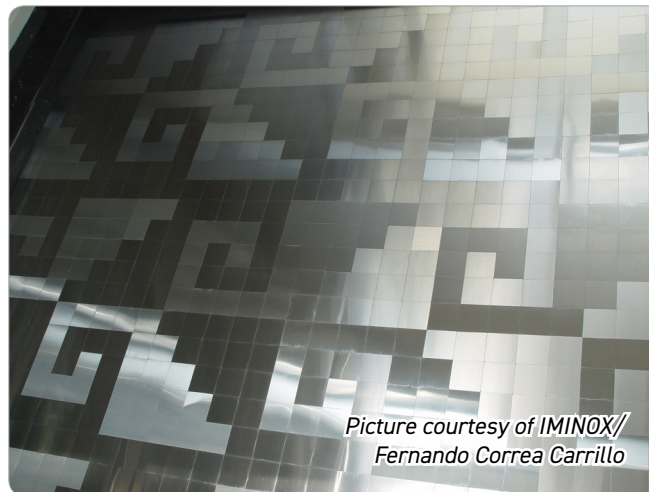

*Picture courtesy of IMINOX/  
Fernando Correa Carrillo*



*Picture courtesy of IMINOX/  
Fernando Correa Carrillo*





## Façade of interior pedestrian hall at Mexico City International Airport

**Name of member:** IMINOX  
**Manufacturer:** Obras de Arte, Inventos, Sueños  
**Field:** Architecture, building and construction  
**Environment:** Indoor  
**Grade and surface:** 304 with interior and exterior polished finish  
**Competing materials:** Glass, carbon steel, aluminum  
**Advantage point for using stainless steel:**

- Esthetic
- Durability
- Modernity
- Easy of rolling to get a particular corrugated shape

The façade contributes because it is an original application in two ways:

- Transform a stainless steel sheet into a unique corrugated shape with a surface finish on both sides
- The stainless allows to place an element of 350 meters length that seems flat

Also Mexico City International Airport has a large number of users, more than 44 million of passengers during 2018, so this highly exposed application is a very effective way to promote the material.



*Picture courtesy of IminoX/Ulises Silva Cruz*

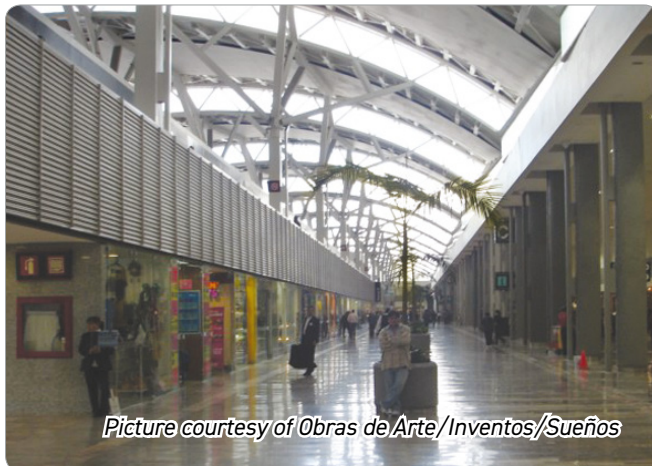

*Picture courtesy of Obras de Arte/Inventos/Sueños*



*Picture courtesy of IminoX/Ulises Silva Cruz*



*Picture courtesy of Obras de Arte/Inventos/Sueños*

## Façade of Liverpool Plaza Toreo Department Store

**Name of member:** IMINOX  
**Manufacturer:** Grupo Básica  
**Field:** Architecture, building and construction  
**Location:** Naucalpan, State of Mexico, Mexico

**Environment:** Urban  
**Grade and surface:** 316L 2B 24 gauge  
**Competing materials:** Stone and phenolics  
**Advantage point of using stainless steel:**

- Easy formability
- Shine
- Corrosion resistance
- Durability
- Free maintenance for difficult access area

The façade of the Liverpool Plaza Toreo Department Store is located in the Periferico Freeway, a road that connects Mexico City with Naucalpan, State of Mexico, which is the busiest road in Mexico City. The façade is very visible for drivers that can view the different tones the façade gets depending on the daylight.

The way to assemble, flat-lock system, seem to be fish scales. This technique of mechanical union avoids the use of welding, adhesives, sealants or liquid elements that could fail and stain the façade by draining them. This arrangement makes the façade waterproof since it allows the water to flow freely over the surface without entering the building, guaranteeing the watertightness. Fish scales are visually also very attractive and undoubtedly attract the attention of people passing through the place. Liverpool Plaza Toreo is the only stainless steel façade of these dimensions in the metropolitan area of Mexico City and the second in the State of Mexico, the first is also of Liverpool Department Store but is located in Interlomas Mall in Huixquilucan State of Mexico. In this way, this façade is a great promoter of stainless in façades, as it is the only one of its kind in Mexico City and located on the busiest road in this city.



## Stainless Steel leading the way to a Safe and Sustainable future

**Name of member:** ISSDA  
**Manufacturer:** Jindal Stainless Ltd.  
**Field:** food and beverage, transport, other  
**Environment:** urban  
**Grade and surface:** 430 (bread moulds), E-rickshaw (304), Fish Cages (304), Display Van (304)

**Competing material:** carbon steel  
**Advantage point of using stainless steel:**  
 Bread Moulds – Present material Aluminium or zinc coated steel is not healthy and hygienic. Stainless Steel offers guarantee.  
 E Rickshaw – Carbon steel corrodes and gives maximum life of 2-3 years. Stainless Steel guarantees minimum 5 year life apart from giving option to reducing weight by 20%.  
 Fish Cages – Carbon steel corrosion and maintenance is a big issue and stainless steel offers better service life.

### 1. Bread Moulds

Contrary to the belief of baking professionals, we established baking in stainless steel. Bread Mould is made in Mild steel & Aluminium now and bread is baked at a temperature of 210-240°C. The moulds are in continuously in the oven baking and are exposed to these temperatures on continuous basis. There is a thick coating of white flour and oil which gets stuck to the mould and becomes black in colour.

Ferritic Grade 430 was used in 0.6 mm thickness and the bread mould was developed in stainless steel.

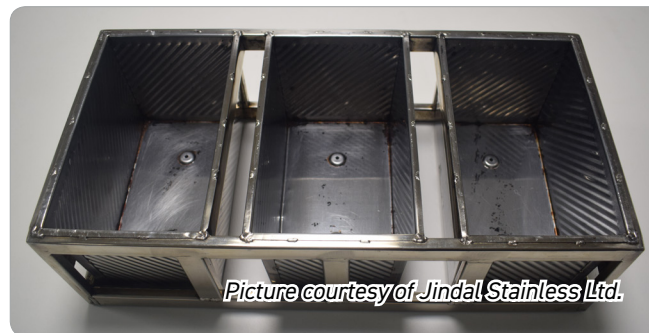

Picture 1: bread moulds

Continuous trials were done on a set of 50 moulds with the leading manufacturer in India and results were fantastic. Baking was achieved with the same parameters and moreover moulds could be cleaned well, making it more hygienic and safe in comparison to the moulds used at present. This will open a good potential for usage of stainless steel in the Baking Industry.

### 2. Electric Rickshaws

With lot of focus on electric vehicles globally, many companies are working on and coming out with new e-vehicles. In India, in one such initiative, electric battery rickshaws are developed and are running to last 5 years. These rickshaws are used for the last mile connectivity mainly from Metro Stations in various cities in the country. All structural frames were developed in mild Steel including the chassis of the rickshaw. Over a period of time, it gets rusted, affects life of the vehicle and also the safety of the passengers. Stainless Steel structural and decorative



Picture 2: eRickshaw



Picture courtesy of Jindal Stainless Ltd.

Picture 3: eRickshaw

pipes were used to build the entire rickshaw in 200 series. Also the floor and seats of the rickshaw were built in stainless steel and laser cut designs were used to improve the aesthetics of the vehicle. This

helped in reducing weight of the rickshaw due to reduction in thicknesses of the pipes used, increased the strength of the vehicle and improved the aesthetic aspects of the vehicle. With these changes, we are expecting to double the life of a rickshaw and the efficiency of the vehicle will also be increased due to less weight.

### 3. Fish Rearing Cage

Worldwide fish rearing cages are being used to nurture and develop fish by providing them proper feed and grains. These cages are built in mild steel, wooden structures and use a big mesh to store fish in ponds and oceans. These structures float in the sea and over a period of time, get rusted or weakened due to salty or high moisture content. Many times, it was observed that structure is broken and this results in safety issues for the fisherman working on



Picture courtesy of Jindal Stainless Ltd.

Picture 4: fish cage

the fisheries cage.

We built the entire cage in stainless steel in austenitic 304 grade with a thickness of 1 mm pipe

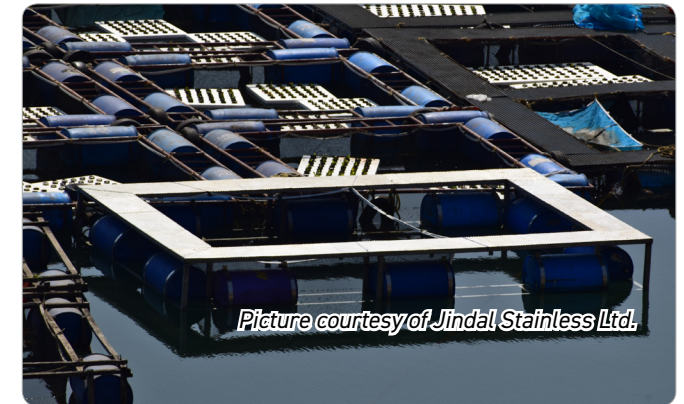

Picture courtesy of Jindal Stainless Ltd.

Picture 5: fish cage

structure. Chequered floors were used on the sides to provide a platform for fishermen to move around to do the development work. We expect the life of the structure will increase 3 times with the usage of stainless steel, reducing corrosion on the structure, thereby adding safety and reducing losses due to broken structure.

#### 4. Display and Training Vehicle

Stainless Steel is gaining usage in Architecture Building & Construction (ABC) and lot of products are developed in stainless steel for household usage. This is an important area where consumers need to be made aware of the new possibilities in stainless steel and also help fabricators make products in stainless steel with good fabrication quality.

A new concept is initiated in the Indian market, where we have developed 2 display vans in stainless steel. These vans showcase the usage of stainless steel in household products i.e. Kitchen & Utensils, Water applications e.g. Overhead water tanks & plumbing pipes, Decor-Cabinets, showcases, etc & study area i.e. furniture, table ware etc. All these applications were displayed in a mobile van comprising of 21 feet display area. Moreover special PVD finishes and chequered floors are also displayed in the van. This van is also equipped with welding and finishing tools to train fabricators on site.



Picture 6: display van

These vans are being extensively used for training and display purposes and are also becoming part of various exhibitions and conferences. Attracting a lot of people in various sectors to develop new products in stainless steel, improve fabrication quality and encourage people to use more and more stainless steel in their household. We have trained more than 8000 fabricators in 85 cities across the Indian subcontinent in the last 2 years.



## A box for home delivery

- Name of member: JFE Steel Corporation  
Manufacturer: NASTA Co., Ltd.  
Field: home and office appliances  
Location: Japan  
Environment: urban, rural, coastal  
Grade and surface: SUS443J1 2D( KD)  
Competing materials: 304 , coated steel  
Advantage point of using stainless steel:
- Excellent corrosion resistance
  - Sparing rare alloy element (Ni and Mo)

Since many kinds of goods are delivered to homes through the internet and other vendors, situations in which the customer is not at home have increased recently. This causes many missed deliveries and is a huge problem for customers and companies. To solve this problem, boxes for home delivery have been introduced.

Since boxes for home delivery are placed in outdoor environments, an attractive appearance and corrosion resistance are required. SUS443J1 with high corrosion resistance provides good formability and a suitable surface finish for painting. Therefore we expect that boxes for home delivery made with this kind of stainless steel will increase.



Picture courtesy of NASTA Co., Ltd.

## Lining for flue duct

**Name of member:** JFE Steel Corporation  
**Manufacturer:** Fujimori Sangyo Co.,Ltd  
**Field:** architecture, building and construction

**Location:** Japan  
**Environment:** industrial  
**Grade and surface:** SUS443J1 2D (KD)  
**Competing material:** 304

**Advantage point of using stainless steel:**

- Low thermal expansion coefficient
- Sparing rare alloy elements (Ni and Mo)

Private power generators have attracted a lot of attention to ensure the power in preparation for an emergency such as an earthquake. Stainless steel has been applied to the inner lining of the flue ducts connecting to the generator. Since the temperature of the lining is very high by exhaust gas, a special structure is required to reduce the thermal strain. Ferritic stainless steel with a low thermal expansion coefficient is essential to reduce the thermal strain and it results in relaxation of the special structure. This contributes to the improvement of workability to line the flue duct with stainless steel.

SUS443J1 with a low thermal expansion coefficient and excellent corrosion resistance against exhaust gas is considered to be suitable for this use.

Therefore we expect that this kind of stainless steel will contribute to the spread of the flue duct market connecting to the private power generator.

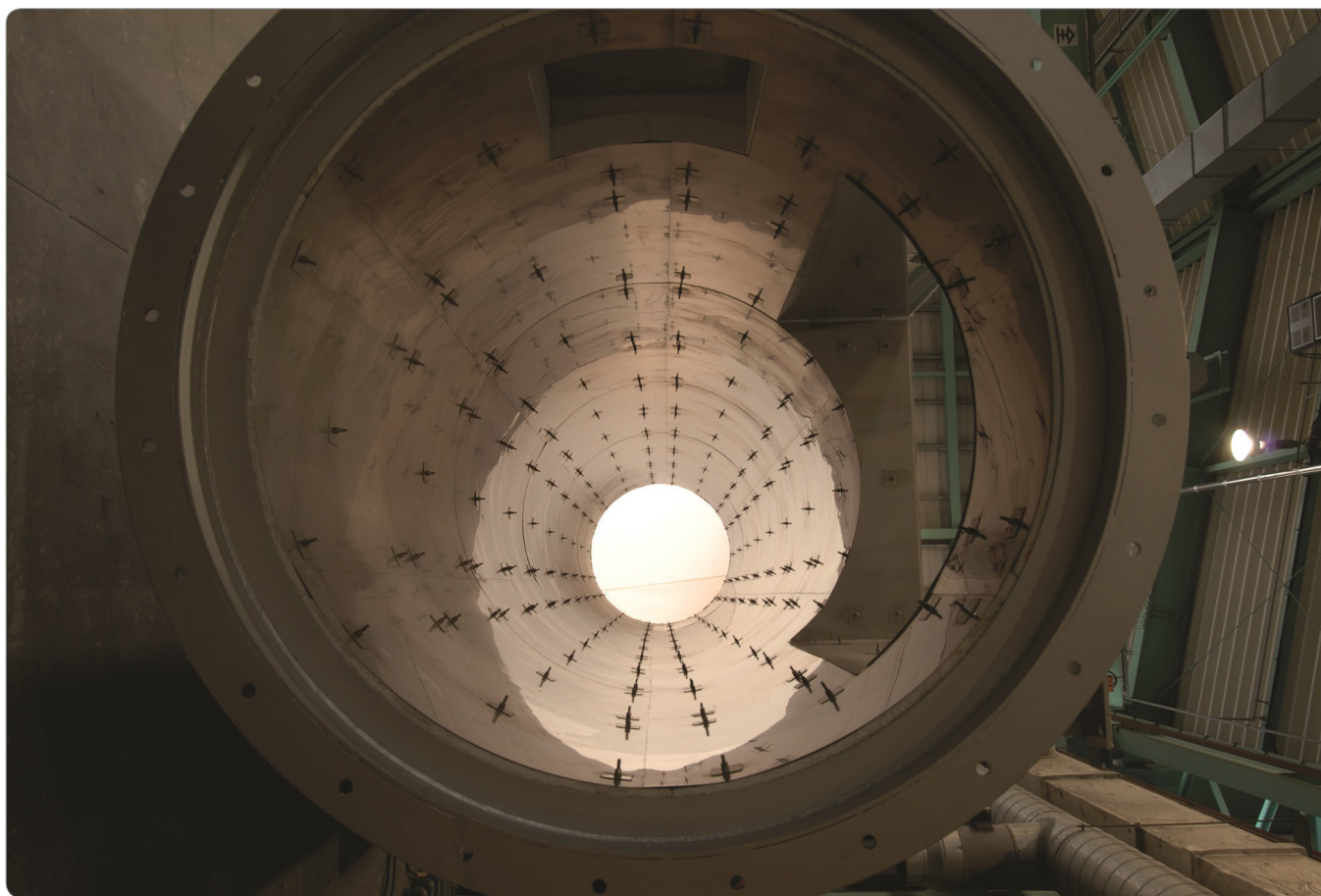

Picture courtesy of Fujimori Sangyo Co., Ltd.



## RFID applied stainless steel food waste measuring & paying equipment

**Name of member:** KOSA  
**Manufacturer:** Tri-s (tri-s.co.kr)  
**Field:** other  
**Location:** Gyeonggido, South Korea  
**Environment:** urban  
**Grade and surface:** STS304/329  
**Competing material:** EGI (Electrolytic Galvanized Iron)

**Advantage point of using stainless steel:**  
 Unlike EGI-coated food waste bins which are prone to rust when exposed to weather and certain conditions, stainless steel bins remain rust resistant over a longer length of time.

Most Koreans live in apartment complexes which have recycling facilities located in communal areas. Each family residing in an apartment complex is able to dispose of their personal food waste into communal food waste bins. These bins use Radio Frequency Identification Devices (RFID) to weigh the waste produced and to charge residents a fee. Stainless steel bins made with STS 304/329 are

ideally suited to collect food waste. High salinity and acidity of food is known to contribute to the surface corrosion of the current food waste bins coated with Electrolytically Galvanized Steel (EGI) over time. In addition, lengthy exposure to the outside elements may also further damage EGI-coated bins. These food waste bins made with STS 304/329 are not as susceptible to rust due to the absence of a coated-surface.

As such, the structural integrity of these bins can endure over a longer period than EGI-coated bins.

The longer durability and easy maintenance of these bins make them a more attractive option to buyers. With communal food waste bins commonly found in apartment complexes throughout Korea and with the increasing awareness of recycling and conscious disposal of waste, there is the opportunity for stainless steel to be used in the food waste area.

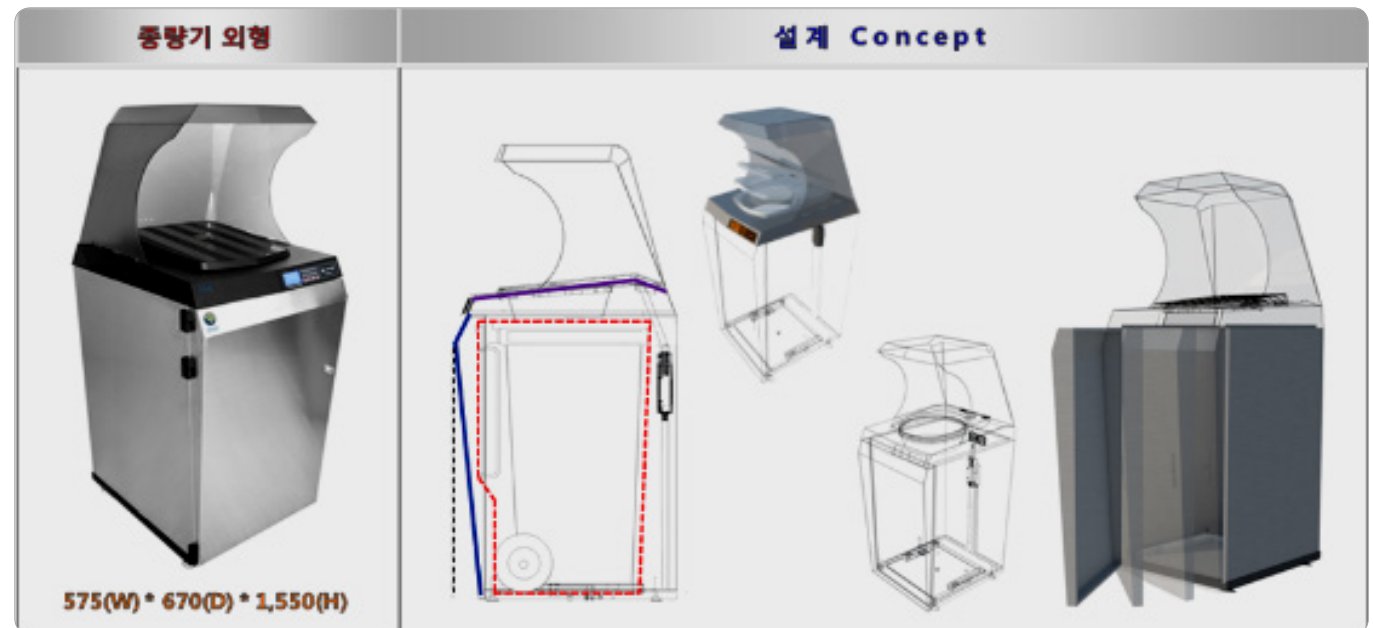





## Modular System



캐노피 (Canopy)

Poly Carbonate

상판/뚜껑 (Upper Plate)

ABS (Acrylonitrile Butadiene Styrene)

뚜껑 개폐장치 (Actuator)

몸체 / 전면도어 / 저울상판

STS 329 FLD (PossSD<sup>2</sup>)

하부구조물 (Base)

ADC 12 (Die Casting)



## Seismic brace for STS pipe

Name of member: KOSA  
 Manufacturer: Justice and peace fire protection engineering company (jpenc.co.kr)  
 Field: architecture, building and construction  
 Location: Incheon, South Korea  
 Environment: industrial  
 Grade and surface: STS304  
 Competing material: GI (Galvanized Iron)  
 Advantage point of using stainless steel: When a carbon steel pipe is used as a fire extinguishing pipe, the sprinkler nozzle may become blocked due to internal corrosion; the fire extinguishing pipe will then fail to function. So it is a tendency to use STS pipe which have good

corrosion resistance. Recently earthquakes have occurred in Korea and anti-seismic design is essential, but STS pipe can't be applied as fire extinguishing pipe because there is no seismic brace. By developing a seismic brace for STS pipes, STS pipes can be used as fire extinguishing pipe.

Fire extinguishing pipes must be installed according to the Fire Service Act. However, in the past, there was no seismic brace for STS pipe, so pipe could not be used as STS steel. The seismic brace for STS pipe was developed to prevent corrosion between dissimilar metals.

\* When carbon steel and STS steel are contacted, it is necessary to insulate because of intermetallic

corrosion.

The fire extinguishing pipe made by STS steel, now capable of anti-seismic design, can be widely used in apartment and building construction sites. If STS steel is used up to the pipe as well as the seismic brace, the actual amount of STS steel used will increase.



COPYRIGHT 2018. JPENC Co., Ltd. all rights reserved.



COPYRIGHT 2018. JPENC Co., Ltd. all rights reserved.

## The sediment discharging facility at the Biratori Dam

**Name of member:** NIPPON STEEL Stainless Steel Corporation  
**Manufacturer:** Marsima Aqua System Corp.  
**Field:** architecture, building and construction  
**Location:** Biratori-cho, Hokkaido  
**Environment:** rural  
**Grade and surface:** NSSC2120 200tons  
 SUS304 350 tons

### Advantage point of using stainless steel:

- Good Appearance (less occurrence of rust on the surface due to its corrosion resistance)
- Abrasion resistance because of its high strength and hardness

Biratori Dam in Hokkaido is under construction to reduce the flood damage in the downstream area at the time of heavy rain, by storing part of the flowing water with Nibutani Dam which is already constructed. Because Biratori Dam is located in one of the heaviest snowfall areas in Japan and the river flows through the bottom of valleys with sheer cliffs, it has been a problem that the sediment abraded by snowslides gets into the river and is piled up in the reservoir.

In order to solve this problem, it was decided to install a sediment discharging facility at the bottom of the dam body. This is the third case in Japan to install such a facility, following Dashidaira Dam

and Unazuki Dam. The facility consists of a sand discharging pipeline made of concrete, and high-pressure gates which are made of SUS304. In addition, it is expected that hard stones which will be piled up at the bottom of the dam will abrade the inner surface of the concrete pipeline; therefore duplex stainless steel NSSC2120, which has high strength and hardness, was applied as lining to protect from abrasion. Approximately 200 tons of NSSC2120 was used, including bolts made of the same grade to attach the lining to the pipeline. Since it could be said that climate change leads to more frequent heavy rain, a lot of dams for flood control are planned to be constructed in Japan, and





these technologies have gathered attention from several countries which are facing similar problems. Moreover, the adoption of stainless steel lining for

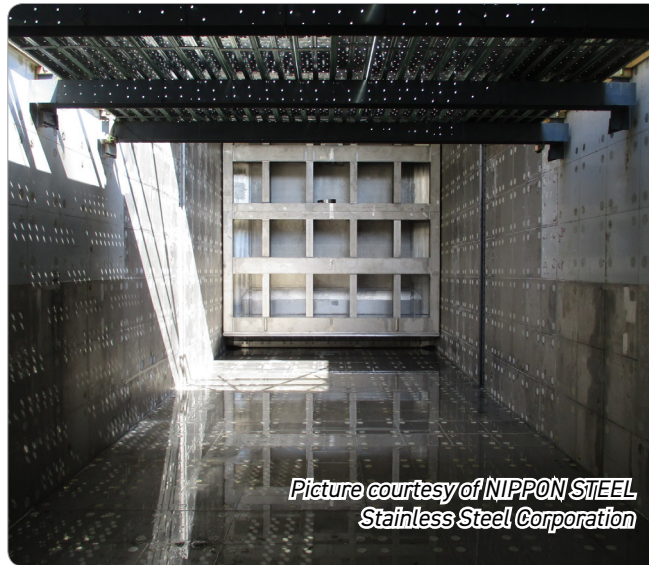

## The Lock Gates of Miyako City Ferry Terminal

- Name of member: NIPPON STEEL Stainless Steel Corporation
- Manufacturer: Marsima Aqua System Corp. , Chuoh Co.
- Field: architecture, building and construction
- Location: Miyako-city, Japan
- Environment: rural, coastal
- Grade and surface: SUS821L1 250 tons
- Competing material: Aluminium alloy
- Advantage point of using stainless steel
- Corrosion resistance
  - High strength (3 times stronger than aluminium alloy)

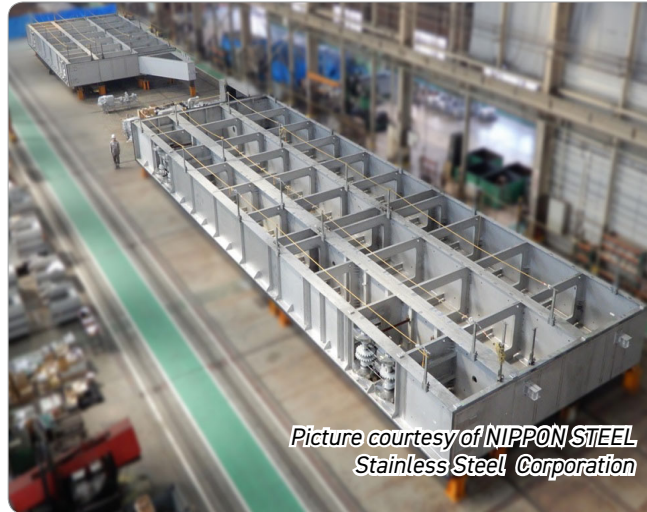

The Sanriku coastal area of Tohoku region has experienced several tsunami disasters as it faces the Pacific Ocean, and a large-scale seawall to prevent disasters is now under construction. Because facilities including fishing ports and ferry terminals are usually located outside (or sea side) of the seawall, people need to get across the seawall from the land side to the sea side in order to reach these facilities.

Lock gates are the gates which are installed at several places of a seawall where people and vehicles can get through.

When the height of seawall is 2m or less, lock gates were usually made of aluminium alloy due to its light weight, because those can be operated manually. Miyako City, located in the Sanriku district,

experienced a tsunami which exceeded 10 meter-high in the Great East Japan Earthquake in 2011. After the disaster, a 9 meter-high seawall was constructed and twenty lock gates of same height were planned to be installed; originally those would be manufactured with aluminium alloy. The larger lock gates must be strong enough against water pressure. The largest lock gate is 9.2 meters-high and it is required to apply extremely thick aluminium alloy plate (which is usually difficult to procure) to withstand increased water pressure. Therefore, duplex stainless steel which has high strength was finally adopted. Duplex stainless steel, which is about 3 times stronger than aluminium

alloy, allowed to reduce not only the weight but also the construction cost. Moreover, SUS821L1, whose specific strength is superior to aluminium alloy, enabled to reduce the girder height as it is not necessary to care deflection, and the appearance of lock gates became much stylish. Approximately 250 tons of stainless steel plates were applied to two large lock gates, and it should be noted that this application created demand of stainless steel in the lock gate market which has long been dominated by aluminium alloys. We will continue to contribute to the reconstruction from the disaster through stainless steel.

## Conveyor Belt Self Unloading Stainless Steel Trailers

Name of member: North American Stainless  
 Manufacturer: Trinity Trailers Mfg Inc  
 Field: transport  
 Environment: rural  
 Grade and surface: T304 2B Finish  
 Competing material: Aluminum  
 Advantage point of using stainless steel:  
 higher strength and corrosion resistance

Profitability in the transport of bulk merchandise by truck depends in great measure on having the equipment that will haul the largest possible payloads at the lowest costs. As the saying goes, "time is money", and this is certainly true in an industry where time not spent on the road means loss of profit. As a result any reduction in the time taken to unload bulk merchandise is time that can be used to deliver one more load. The use of conveyor belt driven self-unloading trailers has proven to be one of the most effective means by which to reduce the unloading time of bulk commodities, resulting in a strong market for companies that produce these types of trailers.

One of the main producers of conveyor belt self-unloading trailers in the U.S. is "TRINITY TRAILER MFG. INC" headquartered in Boise, Idaho. Their "Eagle Bridge" design is a frameless trailer design that provides great strength while remaining light weight, made out of T304 stainless steel for those applications that require superior corrosion resistance.



The major advantage of the conveyor belt self-unloading trailer is the reduced amount of time that it takes to unload. The newest 48" belt width "Eagle Bridge" trailer unloads in less than 4 minutes and once unloaded does not need to be swept of any residue. Due to the fact that the unloading action is achieved by means of a conveyor belt that loops from the bottom of the trailer, the trailer can be parked on uneven ground. This is a great advantage over "tipping chassis" trailers that require flat ground to park.

The frameless design allows the trailer to flex and twist as the trailer moves through different surfaces, due to this flex, the trailer will not break up as many rigid aluminum trailers do.



For a number of products such as fertilizers, food products or wet feeds, corrosion is a major concern,



the best option for transporting these types of merchandise is the use of stainless steel trailers. The stainless trailer utilizes NAS T304 grade stainless for both the panels and tubing that make up the structure. The trailers are both exposed to atmospheric corrosive agents such as salinity and humidity as well as possible corrosive agents

contained in the products being hauled, such as acids, etc. T304 stainless is the perfect choice as it has superior corrosion resistance with a Chrome content of 17% and a Nickel content of 8%. North American Stainless (NAS) supplied the Stainless Steel through "Affiliated Metals" in 2B finish for this application.



## Stainless Steel Highway Sound Barriers

**Name of member:** North American Stainless  
**Manufacturer:** Empire Acoustical Systems  
**Field:** architecture, building and construction  
**Environment:** urban  
**Grade and surface:** T304 2D  
**Competing materials:** Carbon Steel and Galvanized Steel  
**Advantage point of using stainless steel:** corrosion resistance

Most of the Highway sound barriers installed in the U.S are made out of carbon steel or galvanized steel. These barriers undergo a constant process of replacement and maintenance due to the corrosion resulting from the extensive use of road salt during the winter season as well as the humid conditions prevalent in coastal areas. Companies such as "Empire Acoustical Systems" out of Princeton, IL offer the solution by producing barriers made from Stainless Steel. The outer shells of the panels are made with corrosion resistant NAS T304 grade in thickness ranging from 0.8mm to

1.5 mm. The soundproofing core is made with high density mineral wool, the level of sound absorption is extraordinary with levels of NCR of 1.0 and STC of 34 measured per requirements of norm ASTM C423 and ASTM E90.

The panel's size are 12" x 12" and are installed in parallel to make up the sound barrier. The panels are painted to the specifications of the customer, including in some cases where they were painted to mimic the look of wood or other non-metallic elements.



*Picture courtesy of Empire Acoustical Systems*



Stainless Steel Series Silent Screen Panels  
 EMPIRE ACOUSTICAL SYSTEMS





## Stainless Steel Yacht

Name of member: North American Stainless  
 Manufacturer: Cubic Yachts, LLC  
 Field: water equipment  
 Environment: marine  
 Grade and surface: T316L 2D  
 Competing materials: aluminum, fiber glass  
 Advantage point of using stainless steel:  
 corrosion resistance,  
 strength

In today's highly competitive Leisure Boat Industry, in order to stand out, a builder has to produce a boat which combines true innovation in design and materials as well as high standards in luxury and functionality. The company "Cubic Yachts LLC" out of Tampa, Florida has answered the call by building a yacht made out of Stainless Steel with a truly innovative cubic design that attracts a lot of attention wherever it goes.

The building material selected was T316L in 1/4" and 3/8" thickness produced by North American Stainless (NAS) and sourced through Phoenix Metals. The grade was selected due to its high corrosion resistance and strength, making it an ideal choice due to the corrosive environment in which the vessel operates.

Designed by marine architect Fritz Schmid and interior decorator Cheryl Perotti, the Cubic Yacht is a luxury "Mobile Beach House". The vessel is 9,000



square feet including 4,000 of AC space, 3,500 of decks and 1,500 of mechanical and storage. It incorporates 72 solar panels that power the boat in normal operating conditions while charging 160,000 watts of battery storage capacity.

The vessel "Rendezvous 2018" is powered by a Cummins diesel engine and an Azimuth 360 degree channel thruster for excellent maneuverability at speeds of up to seven knots.

Although it can be sailed in open seas due to its seven feet of distance between the water line and the deck, it was designed mainly to be operated in shallow waters close to the coast line where it can

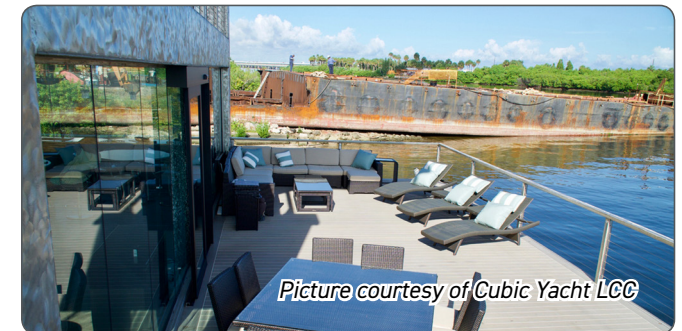

deploy one of the more interesting features. Once it reaches shallow water, the yacht can deploy four 18-foot hydraulic legs with a lifting capacity of a million pounds each, making the boat stand up out of the water so there is no motion of waves or wind.

**Name of member:** Outokumpu Oyj  
**Manufacturer:** Invest Tech  
**Field:** water equipment  
**Environment:** urban  
**Grade and surface:** Forta LDX 2101  
**Advantage point of using stainless steel:**  
 Forta LDX 2101 has enabled an innovative design of wastewater treatment tanks to withstand high water pressure as well as being corrosion-resistant and easily weldable.

Invest-Tech Sp. z o.o. is a Polish company main profile of activity is a service and distribution of stainless steel. As part of the Research and Development Center which was set up in 2012, in order to meet the expectations of innovative solutions for the water protection market [sewage treatment plants], it has successfully undertaken the

design and construction of innovative square panel tanks and duplex steel equipment. These tanks are built out of separate stainless steel segments in a square or rectangular shape so that they can be flexibly extended whenever necessary. Additional flexibility is given as the segments are bolted together and not welded.

The major design challenge for the tanks is the water pressure. A tank with dimensions 23 x 11 x 6 meters (Length x Width x Height), containing 1,200 cubic meters water has to withstand a pressure of approximately 0.6 bar in a straight wall of 23 meters with a deflection of maximum 10 mm only. Outokumpu Forta LDX 2101 duplex stainless steel offers the necessary strength as well as corrosion resistance and good weldability – as there are still some elements that require welding.

The first wastewater treatment plant using Invest-

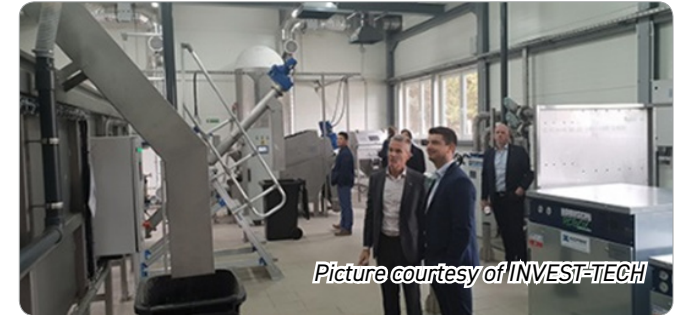

Tech's new tank design, constructed from around 120 tons of Forta LDX 2101 is now in operation in Poland. Invest-Tech is now planning to promote its design in other EU countries as the perfect solution for smaller villages that might need to extend their wastewater treatment capacities in the future.



## Therma grade for a baking furnace used to produce catalysts for oil refining

**Name of member:** Outokumpu Oyj  
**Manufacturer:** Outokumpu Oyj  
**Field:** industrial machinery and equipment  
**Location:** Zibo, China  
**Environment:** industrial  
**Grade and surface:** Outokumpu Therma 253 MA, EN 1.4835, UNS S30815, 1D  
**Competing materials:** 310S and locally produced UNS S30815 plates  
**Advantage point of using stainless steel:** On-site tests have demonstrated a 100% increase on service life over 310S.

The Tianhua Institute of Chemical Machinery & Automation has fabricated a rotary baking furnace used by Sinopec, the Chinese oil and gas enterprise, to produce catalysts for the catalytic cracking of petroleum. It operates at 900°C and is manufactured from Outokumpu 253 MA plates measuring 2000 x 6360 x 18mm. The addition of nitrogen (N), silicon (Si) and cerium (Ce) into the steel provides the plates with higher creep strength and improved corrosion resistance to oxygen. This ensures a longer service life that site tests have shown to be a 100% improvement on 310S.



*Picture courtesy of Tianhua Institute of Chemical Machine & Automation*

## First use of duplex stainless steel Forta LDX 2404, UNS82441 in a major bridge building project

**Name of member:** Outokumpu Oyj  
**Field:** architecture, building and construction  
**Location:** Stockholm, Sweden  
**Environment:** coastal  
**Grade and surface:** Forta LDX 2404, EN 1.4662, UNS82441, 1D & 2E  
**Competing material:** carbon steel  
**Advantage point of using stainless steel:** Long life and low maintenance in a challenging coastal environment ensure lower life cycle costs for bridge structure over a planned 120-year life.

Forta LDX 2404, a new duplex stainless steel from Outokumpu, standardised as grade EN 1.4662 and UNS82441 has been selected for its first major structural project, the Söderström rail bridges in Stockholm.

The Söderström network comprises four bridges carrying metro trains, each approximately 174 m in length between the districts of Slussen and the Old Town in Stockholm. The bridges are owned by Stockholm City and were originally built in 1957 with their superstructure constructed from welded carbon steel. The tracks are intensively used, carrying 340,000 people per day by metro with an average of one train every three minutes.

An assessment carried out in 2013 by the Swedish traffic authority, Trafikverket, concluded that extensive corrosion attack required the old carbon steel superstructure to be replaced. With a Pitting

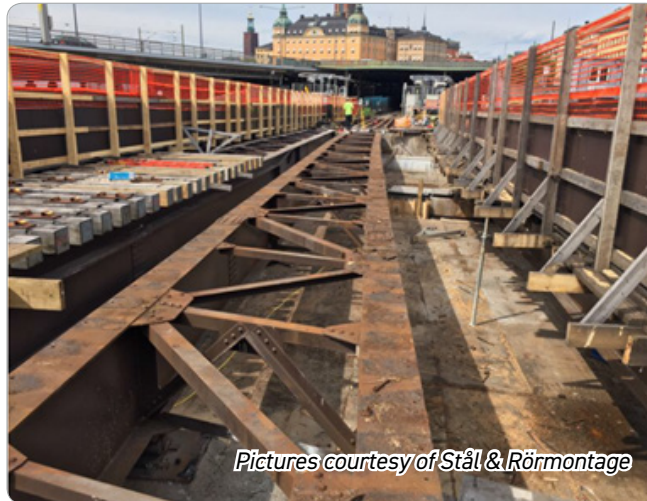

*Pictures courtesy of Stål & Rörmontage*

*Picture 1: the old and corroded carbon steel structure, to be replaced*

Resistance Equivalent, PRE of approximately 33, Forta LDX 2404 fills a gap between standard duplex grades UNS S32304 and UNS S32205. In addition, it has higher strength than these standard duplex grades, making it particularly suitable for structural applications. A comparison of a replacement structure constructed from painted carbon steel to a structure in Forta LDX 2404 duplex stainless steel was undertaken by Swedish engineering consulting firm Bostek. This study concluded that the low maintenance requirement of Forta LDX 2404 duplex stainless steel gave a significant reduction in the



*Pictures courtesy of Stål & Rörmontage*

*Picture 2: Fabrication at Stål & Rörmontage workshop*

120 year whole life costs, despite higher initial costs compared to carbon steel. Outokumpu has supplied 600 tonnes of plate material. Fabrication of welded sub-assemblies was carried out at Outokumpu Plate Service Centre, Sweden, before supply to Stål & Rörmontage for final fabrication of 48 bridge parts and final assembly on site. The final duplex stainless steel structure will not be visible during service, but the significant benefit is the reduction in need for maintenance which gives significant cost savings and reduces maintenance disruption to the rail system.



*Pictures courtesy of Stål & Rörmontage*

*Picture 3: Installation of new structure in grade Forta LDX 2404*

This project represents a significant advancement, as it demonstrates that Forta LDX 2404 duplex stainless steel can be used in a major bridge engineering project on the basis of Life Cycle Cost and other whole life benefits, without regard to aesthetic benefits that are often a reason for use of stainless

steels in architecture and building applications. In addition, it shows that Forta LDX 2404 can be considered as a competitor to carbon steel and that duplex stainless steel has a significant future potential in bridge applications.



## Lightweight stainless steel fuel filler neck for automobiles

Name of member: POSCO  
 Manufacturer: SAMBO Motors  
 Field: automotive, transport  
 Location: Korea, US  
 Environment: urban, rural, industrial  
 Grade and surface: 304XD and 2B  
 Competing materials: Carbon steel and Engineering plastic

**Advantage point of using stainless steel:**  
 The developed material is used to fabricate the fuel filler neck of automobiles having advantages of lightweight, longer lifetime and easy recycling.

Harmful air pollution in large cities is largely originated from cars, trucks and buses. More strict regulations are laid on the automobile manufactures to produce the vehicles which can meet the emission requirement. A lighter car by reducing a vehicle's weight can significantly improve fuel efficiency and reduce exhaust gas.

Conventional fuel filler necks are made of carbon steel or engineering plastic. Carbon steel is cheap and has good formability to be fabricated. However, due to low corrosion resistance of the material, multiple protective paintings and coatings could not guarantee the required product's lifetime (e.g. 15 years/150k miles of California Vehicle and Emissions Warranty Periods). Engineering plastic has a couple of advantages of lightweighting and manufacturing of complex shaped parts. This material, however, has poor crashworthiness, the lack of fire resistance and



Picture 1: fuel filler neck

difficulties in recycling.

A new austenitic stainless steel is designed to assist customer's development of an eco-friendly fuel filler neck having lightweight, longer product's lifetime and easy recycling. The chemical composition of the developed material lies in the range of Type 304. The content of copper is optimized and the cold rolling technology is developed to have sufficient ductility in the multi-stage forming of the fuel filler neck preventing cracks during fabrication, and delayed cracks, which are the detrimental property of austenitic stainless steel after severe forming. When conventional Type 304 is applied, multiple cracks occur at the final stage of fabrication. In case of the new 304XD, no cracks are observed. In addition, approximately 30% of weight reduction is accomplished with respect to a carbon steel fuel filler

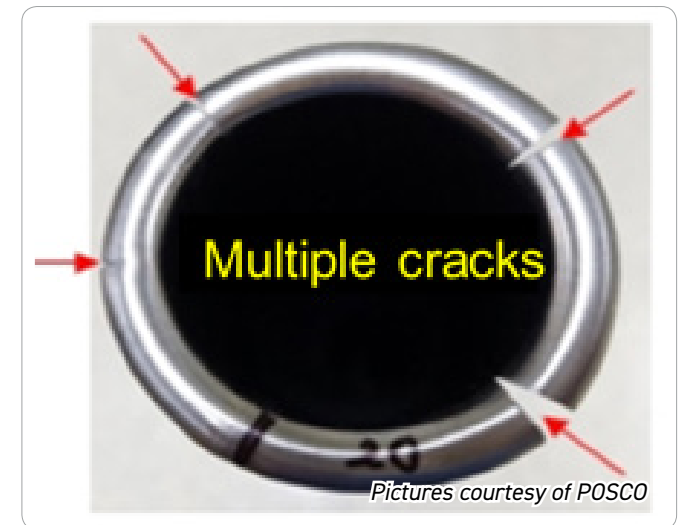

Picture 2: Multiple cracks after forming (Conventional Type 304)



neck having the same geometry by accounting for the prominent higher strength of austenitic stainless steel. No external coating or the minimal powder-type coating for surface protection has to be applied owing to good corrosion resistance.

The excellent formability and ductility of POSCO 304XD can be further utilized in other applications such as sinks and deep drawing parts. This material

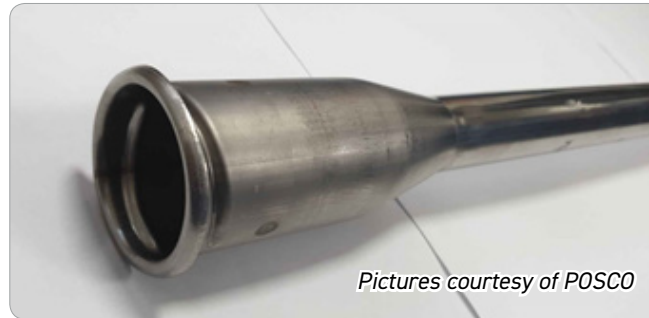

Picture 3: No cracks after forming (POSCO 304XD)

also can be used in hydroforming where severe compressive deformation often causes delayed cracking. More applications could be sought by taking advantages of the lightweight design by higher strength, longer lifetime with good corrosion resistance and easy recycling helping the protection of world environment.



## Stainless Steel New Applications in Nigeria

**Name of member:** SSDAN  
**Field:** art and street furniture; architecture, building and construction; food and beverage; home and office appliances  
**Location:** Lagos and Abuja, Nigeria  
**Environment:** urban, rural, indoor  
**Grade and surface:** Grade 304, Polish (Mirror)  
**Competing materials:** Steel (Foreign wrought iron) and Aluminium

**Advantage point of using stainless steel:**  
 Stainless steel grade 304 does not rust because chromium and nickel components.  
 Stainless steel has little or no maintenance cost.  
 Stainless steel aesthetic in nature.  
 Stainless steel is self-cleansing.

Stainless steel grade 304 is widely use in Nigeria. However, it faces fierce competition from Aluminium and Foreign Wrought Iron especially in the southern and western region of Nigeria because of the terrain. The water in those regions contain high levels of salt, so most users who domicile there prefer to use Aluminium or Foreign Wrought Iron material ONLY for their handrails instead of Stainless steel grade 304.

Nevertheless, the stainless steel market is under developed because all the stainless steel materials we consume are imported and the demand of stainless steel is increasing geometrically because of

the wide range of applications. Lastly, stainless steel grade 304 is affordable compared to stainless steel grade 316 and it has the ability to fight corrosion efficiently.



Globe



Towel hanger

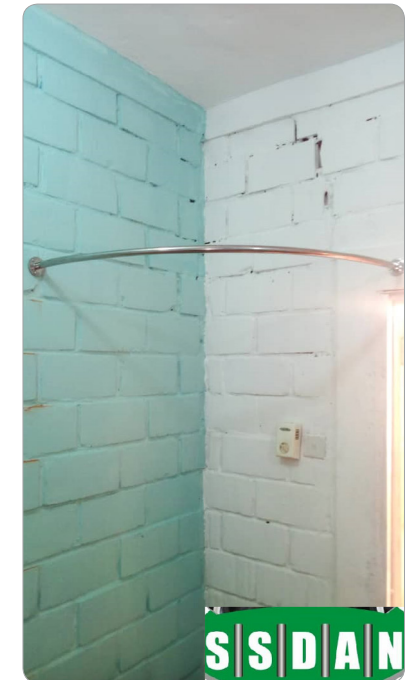

Shower curtain hanger





Cart



Glass table



Fence rail

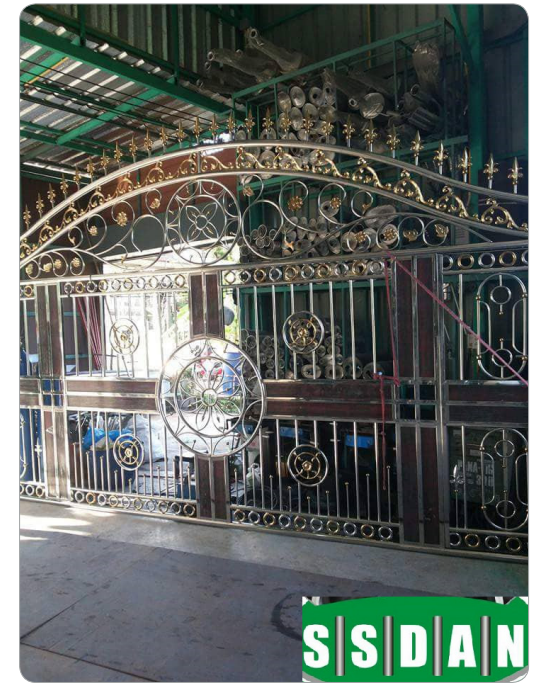

Gate

## High Nitrogen (above 2000ppm) and Low Nickel (~3.0%) alloyed High Strength Austenite Stainless Steel (QN1803/304D) with no less Pitting Corrosion Resistance than standard 304

**Name of Member:** Tsingshan Industry  
**Manufacturer:** Tsing Tuo Group Co.,Ltd, a Tsingshan Holding Company  
**Field:** art and street furniture; architecture, building and construction; electrical machinery and equipment; cookware, hollowware and cutlery; industrial machinery and equipment; home and office appliances; transport  
**Location:** Ningde City, Fujian Province, the People's Republic of China  
**Environment:** urban, rural, industrial, indoor  
**Grade and surface:** QN1803/304D - No.4/2B/NO.1

**Competing materials:** S30408, S30403  
**Advantage point of using stainless steel:**  
 1. Pitting corrosion resistance for new developed QN1803/304D austenitic stainless steel is no less than 304.  
 2. Higher yield strength (355 Mpa) for QN1803/304D than 304 (235Mpa).  
 3. Better polish ability for QN1803/304D than 304.  
 4. Lower nickel and thus lower production costs

304 standard austenitic stainless steel with 18Cr-8Ni alloyed, has been extensively applied in various applications due to its excellent workability, corrosion resistance, formability and weldability for over half a century. The strength of 304 at annealed condition is, however, too low, being only at 235MPa level, which could not meet well the requirements in many fields, such as construction and building,

art and street furniture, home and office appliance, cookware, transport, etc, where corrosion resistance and hardness or yield strength should be maintained high. In addition, 8% nickel gives the product of 304 a high alloy cost and also a risk as the nickel price fluctuates. Because of its low corrosion resistance, the standard high manganese and 3~4%Ni alloyed 200 series austenitic stainless steel can not replace

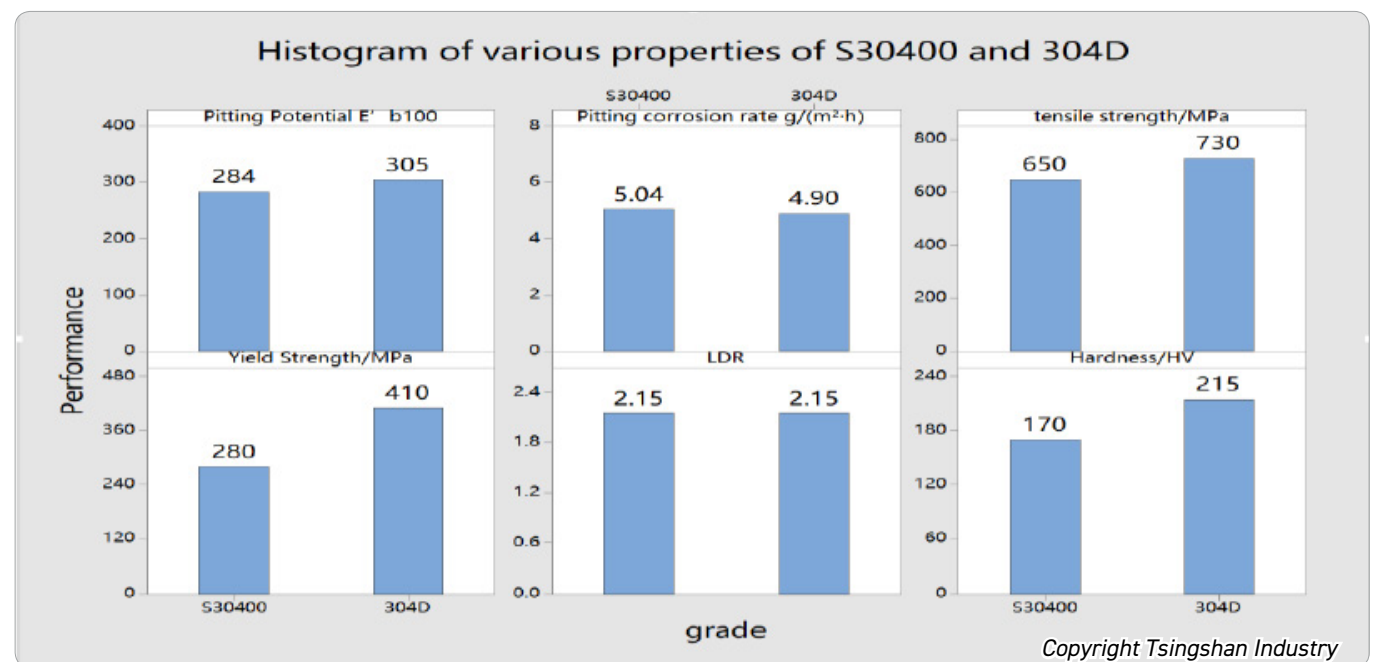



304 in those applications although it has much higher strength.

There is, therefore, an urgent need for developing a new type of austenitic stainless steel with no less than corrosion resistance and higher strength and even lower cost as compared to 304 in those applications where both corrosion resistance and strength are highly required. Tsingtuo Group, a Tsingshan Industry Holding Company, has developed QN1803/304D by alloying with very high nitrogen (above 2000MPa), the same amount of chromium (18%) and lower nickel (~3%) but higher copper (1.70%) as compared with 304.

The technical properties in terms of pitting potential, pitting corrosion rate, mechanical strength and LDR is shown as follows. Obviously, QN1803/304D has higher pitting potential, lower pitting corrosion rate,

Grade	C	Si	Mn	P	S	Cr	Ni	Mo	Cu	N	PREN*	MD30
304	0.045	0.40	1.02	0.037	0.004	18.20	8.02	0.04	0.15	0.046	18.63	10.37
304D	0.068	0.40	6.30	0.038	0.002	18.18	3.05	0.10	1.65	0.242	19.47	-35.72

$$PREN^*=Cr+3.3Mo+30N-Mn$$

Copyright Tsingshan Industry

higher yield and tensile strength and hardness and similar LDR compared to 304. Those good properties give QN1803/304D a very good platform to replace 304 in many application fields. The invention patent for QN1803/304D product has been applied. Until now, over 10,000 tonnes have been produced

and applied in terms of cold strip, hot strip and wire rod in the Chinese market, such as decoration tubular products, decoration panels, building roof, cookware, springs and fasteners, etc., with the representative pictures shown below and on the next page.

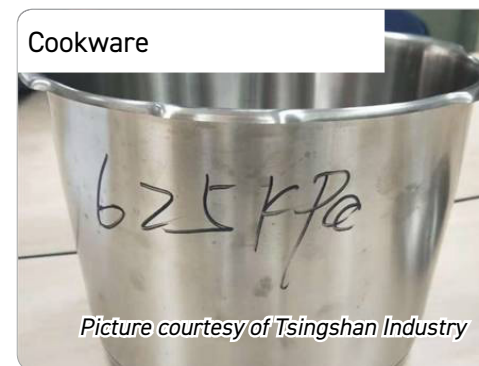
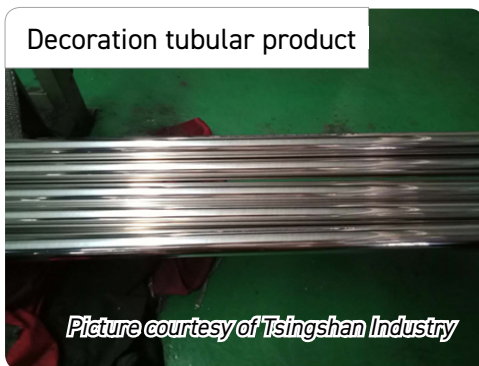



Fastener



*Picture courtesy of Tsingshan Industry*

Fastener



*Picture courtesy of Tsingshan Industry*

Building roof



*Picture courtesy of Tsingshan Industry*

Spring

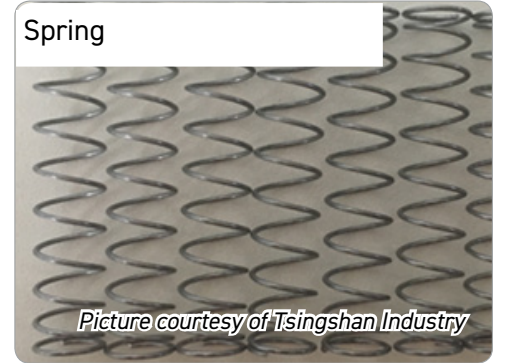

*Picture courtesy of Tsingshan Industry*



## Help

Help page

Contents page.

Previous page.

Next page.

Previous view.

## About ISSF

The International Stainless Steel Forum (ISSF) is a non-profit research and development organisation which was founded in 1996 and which serves as the focal point for the international stainless steel industry.

### Who are the members?

ISSF has two categories of membership: company members and affiliated members. Company members are producers of stainless steel (integrated mills and rerollers). The association has 56 members from all over the world and currently represents approximately 90% of the total production of stainless steel.

### Vision

Stainless steel provides sustainable solutions for everyday life.

### More information

For more information about ISSF, please consult our website [worldstainless.org](http://worldstainless.org).

For more information about stainless steel and sustainability, please consult the [sustainablestainless.org](http://sustainablestainless.org) website.

## Contact us

[issf@issf.org](mailto:issf@issf.org)

+32 2 702 89 00

### Disclaimer

The International Stainless Steel Forum believes that the information presented is technically correct. However, ISSF, its members, staff and consultants specifically disclaim any and all liability or responsibility of any kind for loss, damage, or injury resulting from the use of the information contained in this brochure.





[worldstainless.org](http://worldstainless.org)